

Operator's Manual

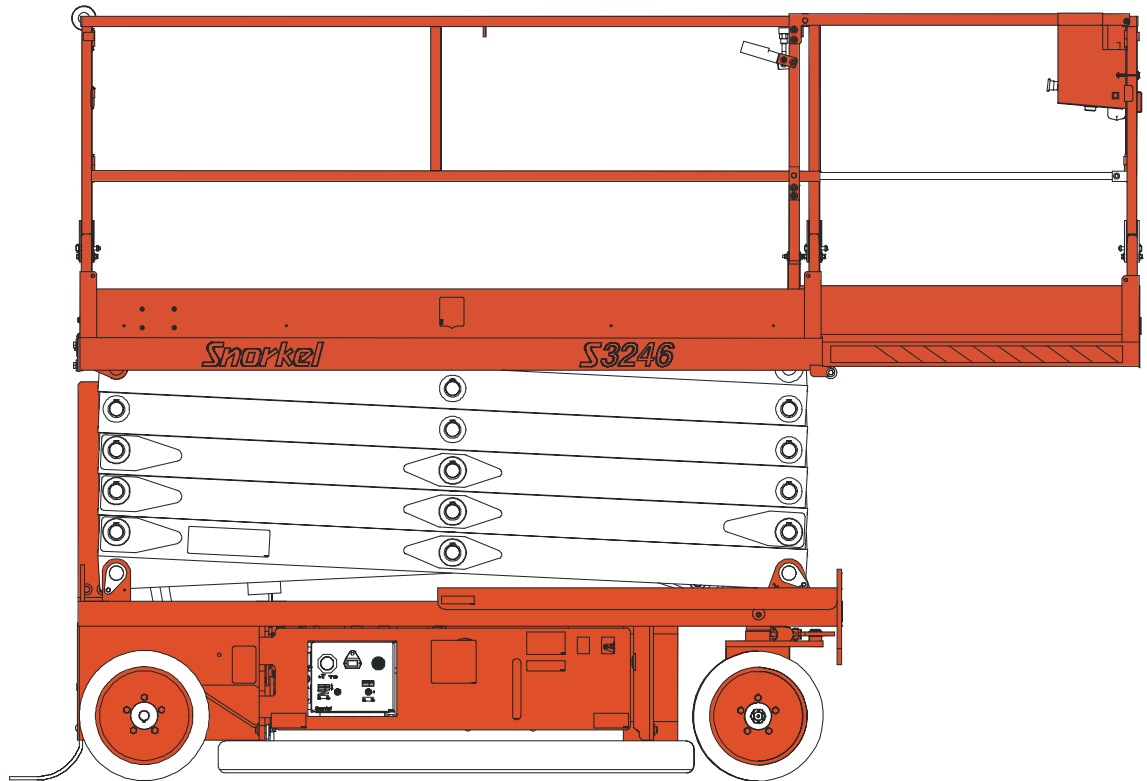

S2646

S3246

DANGER

The aerial platform is not electrically insulated. Death or serious injury will result from contact with, or inadequate clearance from, an energized conductor.

Do not go closer than the minimum safe approach distance as defined by the Minimum Safe Approach Distance section in Chapter 3 – Safety.

Regard all conductors as energized.

Allow for electrical wire sag and aerial platform sway.

If the platform, scissors structure, or any part of the aerial platform contacts a high-voltage electrical conductor, the entire machine can become electrically charged.

If that happens, remain on the machine and do not contact any other structure or object. This includes the ground, adjacent buildings, poles, and any other objects that are not part of the aerial platform.

Such contact could make your body a conductor to the other object, creating an electrical shock hazard resulting in death or serious injury.

If an aerial platform is in contact with an energized conductor the platform operator must warn ground personnel in the vicinity to stay away. Their bodies can conduct electricity creating an electrical shock hazard resulting in death or serious injury.

Do not approach or leave the aerial platform until the electricity has been turned off.

Do not attempt to operate the lower controls when the platform, scissors structure, or any part of the aerial platform is in contact with a high-voltage electrical conductor or if there is an immediate danger of such contact.

Personnel on or near an aerial platform must be continuously aware of electrical hazards, recognizing that death or serious injury can result from contact with an energized conductor.

Table of Contents

Chapter 1 – Introduction

Aerial Platform Features	1
Options	1
Operator's Manual	1
Safety Alerts	1
Operation	1
Maintenance	2
Owner and User Responsibilities	2
Additional Information	2

Chapter 2 – Specifications

Component Identification	3
General Specifications S2646	4
Aerial Platform	4
Platform	4
Function Speed	4
Drive System	4
Drive/Lift Level Sensor Interlock	4
Tires	4
Electrical System	4
Hydraulic System	4
Ambient Air Temperature Operating Range	4
Maximum Wind Speed	4
Vibration	4
Sound Threshold	4
General Specifications S3246	5
Aerial Platform	5
Platform	5
Function Speed	5
Drive System	5
Drive/Lift Level Sensor Interlock	5
Tires	5
Electrical System	5
Hydraulic System	5
Ambient Air Temperature Operating Range	5
Maximum Wind Speed	5
Vibration	5
Sound Threshold	5

Chapter 3 – Safety

Electrocution Hazards	7
Minimum Safe Approach Distance	7
Prestart Inspection	8
Work Place Inspection and Practices	8
Operation	8
Tip-Over and Falling Hazards	8
Electrical System	9
Hydraulic System	9
Placards and Decals	9

Chapter 4 – Safety Devices

Emergency Stop Controls	11
Drive Motion Alarm	11
Pothole Protector Skids	11

Drive/Lift Pothole Protector Interlock	12
Drive/Lift Level Sensor Interlock	12
Lowering Alarm	12
Lowering Interrupt	12
Emergency Lowering Handle	12
Safety Prop	12
Guardrails	13
Horn	13
Tilt Alarm	13
Overload Protection	13
Flashing Light	13

Chapter 5 – Gauges and Displays

Hour Meter	15
Ammeter	15
Battery Condition Indicator	15

Chapter 6 – Batteries

General Maintenance	17
Charging	17

Chapter 7 – Controls

Battery Disconnect Switch	19
Lower Controls	19
Emergency Stop Button	19
Control Selector Switch	19
Platform Raise/Lower Switch	19
Upper Controls	19
Emergency Stop Button	20
Drive/Lift Selector Switch	20
Joystick	20
Interlock	20
Steer Switch	20
Drive Range Switch	20
Horn Button	20
Battery Condition Indicator	20

Chapter 8 – Prestart Inspection

Operator's Manual	21
Electrical System	21
Battery Fluid Level	21
Battery Terminals	21
Battery Charger	21
Safety Prop	22
Cables and Wiring Harness	22
Hydraulic System	23
Fluid Level	23
Hoses and Fittings	23
Free-Wheeling Valve	23
Tires and Wheels	24
Ground Strap	24
Lower Control Station	24
Operating Controls	24
Emergency Stop	24

Table of Contents

Lowering Alarm and Interrupt	24
Pothole Protector Interlock	24
Emergency Lowering	25
Structures	25
Weldments	25
Slide Pads	26
Fasteners	26
Upper Control Station	26
Guardrail System	26
Platform Extension	26
Swing-Down Rails	27
Brakes	27
Operating Controls	27
Emergency Stop	27
Horn	27
Lowering Alarm and Interrupt	28
Drive Motion Alarm	28
Flashing Light	28
Battery Condition Indicator	28
Placards and Decals	28
Prestart Inspection Checklist	31

Chapter 9 – Operation

Preparing for Operation	33
Lower Controls	33
Upper Controls	33
Driving	34
Drive Range Switch	34
Drive Speeds	34
Drive/Lift Level Sensor Interlock	35

Steering	35
Platform	35
Raising and Lowering	35
Lowering Interrupt	35
Overload Protection	35
Extending	36
Swing-Down Rails	36
Swing-Out Trays	37
Wallboard Loading	37

Chapter 10 – Stowing and Transporting

Stowing	39
Transporting	39
Lifting With a Forklift	39
Winching	39
Driving	40
Hoisting	41
Securing for Transport	42

Chapter 11 – Emergency Operation

Emergency Lowering	43
Towing	43

Chapter 12 – Troubleshooting

Troubleshooting Chart	45
-----------------------------	----

Appendix A – Glossary

Limited Warranty

Chapter 1 – Introduction

Aerial Platform Features

The aerial platform is a self-propelled scissors lift that has been designed to raise personnel, their tools, and material to the workstation. The S2646 has one hydraulic cylinder to raise and lower the platform and the S3246 has two cylinders. A hydraulic motor on each of the front wheels provides power to move the aerial platform.

The standard machine includes the following features.

- Proportional drive and lift up control
- Drivable at full height
- Drive motion alarm
- Non-marking tires
- Automatic pothole protection system
- Level sensor with drive/lift interlock
- Hour meter
- Manual lowering valve
- Lockable battery disconnect switch
- Tie-down lugs
- Lifting lugs
- Heavy duty battery charger with ammeter
- Swing-out hydraulic and electrical component trays
- Non-slip metal platform floor
- 0.9 m (3') platform extension
- Swing-down platform rails
- 125 volt AC electrical outlet with GFCI
- Scissor arm safety support prop
- Lowering alarm
- Removable upper controls
- Horn
- Forklift loadable from three sides
- Rear forklift pockets
- Platform entry gate with gravity gate
- Keyed control selector switch
- Five year limited warranty

The aerial platform has been manufactured to conform to European Directive 98/37/EC and European Standard EN280.

Options

The following options may be provided on the machine.

- Flashing light
- Battery condition indicator

Operator's Manual

This manual provides information for safe and proper operation of the aerial platform. Because it covers more than one model, some figures may only represent what is actually on the machine. Read and understand the information in this Operator's Manual before operating the aerial platform on the job.

Additional copies of this manual may be ordered from Snorkel. Supply the model and manual part number from the front cover to assure that the correct manual will be supplied.

All information in this manual is based on the latest product information at the time of publication. Snorkel reserves the right to make product changes at any time without obligation.

Safety Alerts

A safety alert symbol is used throughout this manual to indicate danger, warning, and caution instructions. Follow these instructions to reduce the likelihood of personal injury and property damage. The terms danger, warning, and caution indicate varying degrees of personal injury or property damage that can result if the instruction is not followed.

Danger

Indicates an imminently hazardous situation which, if not avoided, will result in death or serious injury. This signal word is to be used in the most extreme situations.

Warning

Indicates a potentially hazardous situation which, if not avoided, could result in death or serious injury.

Caution

Indicates a potentially hazardous situation which, if not avoided, may result in minor or moderate injury. It may also be used to alert against unsafe practices.

Notes

Notes are used to provide special information or helpful hints to assist in aerial platform operation, but do not indicate a hazardous situation.

Operation

The aerial platform has built-in safety features and has been factory tested for compliance with Snorkel specifications and industry standards. However, any personnel lifting aerial platform can be potentially dangerous in the hands of untrained or careless operators.

Warning

The potential for an accident increases when the aerial platform is operated by personnel who are not trained and authorized. Death or serious injury can result from such accidents. Read and understand the information in this manual and on the placards and decals on the machine before operating the aerial platform on the job.

Training is essential and must be performed by a qualified person. Become proficient in knowledge and actual operation before using the aerial platform on the job. You must be trained and authorized to perform any functions of the aerial platform. Operation of the aerial platform must be within the scope of the machine specifications.

The operator bears ultimate responsibility for following all manufacturer's instructions and warnings, regulations and safety rules of their employer and/or any state or federal law.

Maintenance

Every person who maintains, inspects, tests, or repairs the aerial platform must be qualified to do so. Following the daily prestart inspection in this Operator's Manual will help keep the aerial platform in optimum working condition. Other maintenance functions must be performed by maintenance personnel who are qualified to work on the aerial platform.

Do not modify this aerial platform without prior written consent of the Snorkel Engineering Department. Modification may void the warranty, adversely affect stability, or affect the operational characteristics of the aerial platform.

Owner and User Responsibilities

All owners and users of the aerial platform must read, understand, and comply with all applicable regulations. Ultimate compliance to national safety regulations is the responsibility of the user and their employer.

Additional Information

For additional information contact your local dealer or Snorkel at:

Snorkel International
P.O. Box 1160
St. Joseph, MO 64502-1160 USA
785-989-3000

<http://www.snorkelusa.com>

Chapter 2 – Specifications

Component Identification

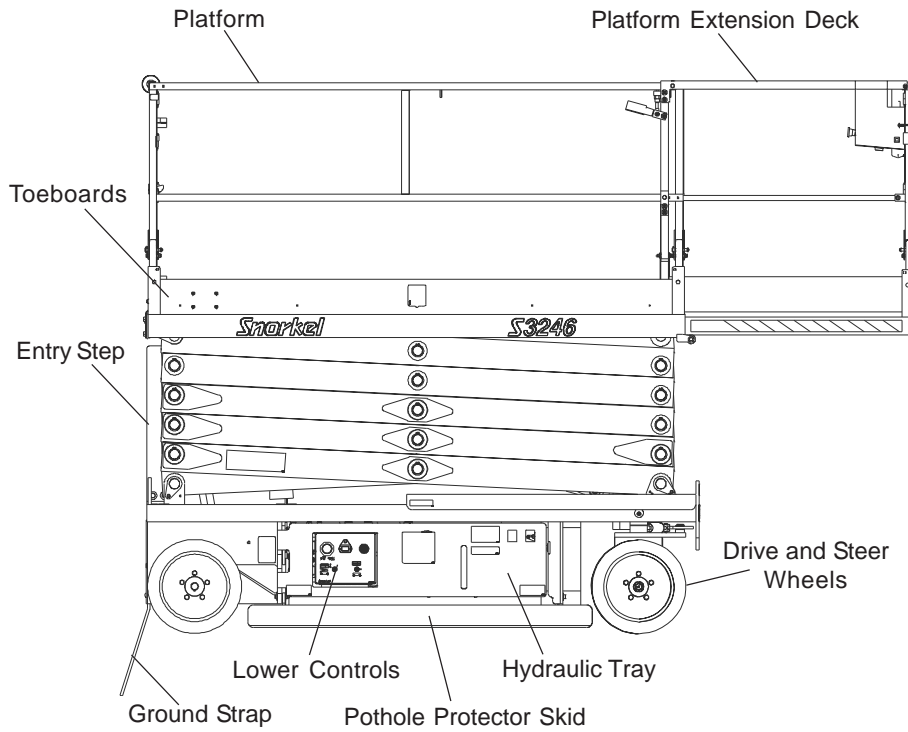

Right Side

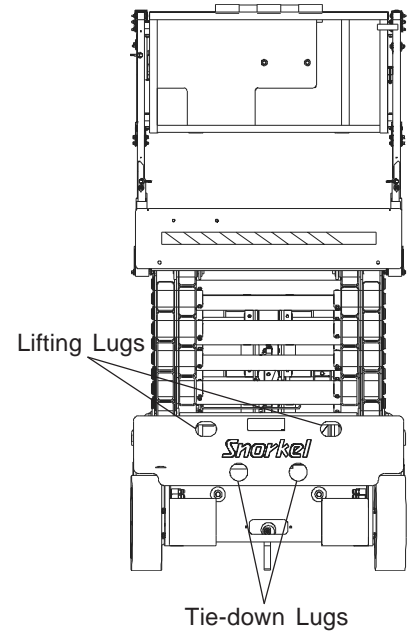

Front

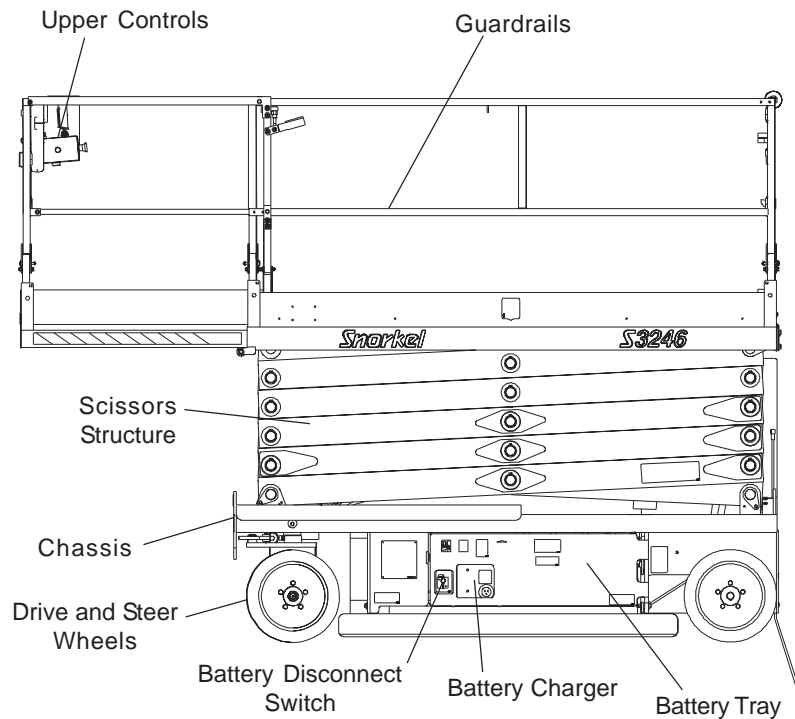

Left Side

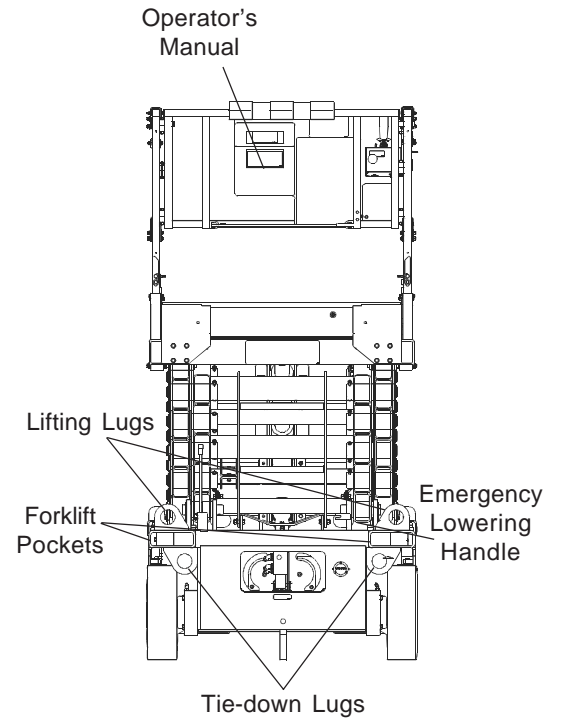

Rear

General Specifications S2646

Aerial Platform

Working height	9.75 m (32')
Maximum platform height	7.9 m (26')
Turning radius	
Inside	25.4 cm (10")
Outside	2.5 m (101")
Wheelbase	1.9 m (75")
Ground clearance	
Pothole protector raised	10.1 cm (4")
Pothole protector lowered	2.5 cm (1")
Maximum wheel load	1125 kg (2,480 lbs)
Maximum ground pressure	11.7 kg/cm ² (166 psi)
Weight, GVW	
Approximate	2359 kg (5,200 lbs)
Stowed width	116.8 cm (46")
Stowed length	254 cm (100")
Stowed height	
Guardrails raised	236.2 cm (93")
Guardrails lowered	167.6 cm (66")

Platform

Dimensions	
Main	114.3 cm x 238.7 cm (45" x 94")
Extension	104.1 cm x 91.4 cm (41" x 36")
Total length with extension	330.2 cm (130")
Rated work load	
Total	453.5 kg (1,000 lb)
Extension	113.3 kg (250 lb)
Maximum number of occupants	
Outside	1 person
Inside	3 people

Function Speed

Platform raise	25 to 35 seconds
Platform lower	50 to 60 seconds
High drive	
Platform lower than 2.1 to 2.4 m (7 to 8 feet)	3.2 km/h (0 to 2 mph)
Low drive	
Platform higher than 2.1 to 2.4 m (7 to 8 feet)	0.8 km/h (0 to 0.5 mph)

Drive System

Standard	Two wheel drive
Gradeability	25%
Maximum drive height	10.9 m (26')

Drive/Lift Level Sensor Interlock

Side-to-side	2 degrees
Front-to-rear	4 degrees

Tires

Nonmarking solid rubber	40.6 cm x 12.7 cm (16" x 5")
-------------------------	------------------------------

Electrical System

Voltage	24 V DC negative chassis ground
Source	Four - 6 V 240 amp hour batteries
Fluid recommended	distilled water
Charger	40 amp

Hydraulic System

Maximum pressure	21,373.75 kPa (3,100 psi)
Reservoir capacity	34 l (9 US gal)
System capacity	35 l (9.25 US gal)
Maximum operating temperature	71°C (160°F)
Hydraulic fluid recommended	
Above -13°C (10°F)	Mobil DTE-13M (ISO VG32)
Below -13°C (10°F)	Mobil DTE-11M (ISO VG15)

Ambient Air Temperature Operating Range

Celsius	-18°C to 43°C
Fahrenheit	0°F to 110°F

Maximum Wind Speed

Gust or steady	12.5 m/s (28 mph)
----------------	-------------------

Vibration

less than 2.5 m/sec²

Sound Threshold

below 70 dB(A)

General Specifications S3246

Aerial Platform

Working height	11.58 m (38')
Maximum platform height	9.75 m (32')
Turning radius	
Inside	25.4 cm (10")
Outside	2.5 m (101")
Wheelbase	1.9 m (75")
Ground clearance	
Pothole protector raised	10.1 cm (4")
Pothole protector lowered	2.5 cm (1")
Maximum wheel load	1328 kg (2,928 lbs)
Maximum ground pressure	13.8 kg/cm ² (196 psi)
Weight, GVW	
Approximate	3003 kg (6,620 lbs)
Stowed width	116.8 cm (46")
Stowed length	254 cm (100")
Stowed height	
Guardrails raised	251.4 cm (99")
Guardrails lowered	182.8 cm (72")

Platform

Dimensions	
Main	45" x 94" (114.3 cm x 238.7 cm)
Extension	41" x 36" (104.1 cm x 91.4 cm)
Total length with extension	130" (330.2 cm)
Rated work load	
Total	317.5 kg (700 lb)
Extension	113.3 kg (250 lb)
Maximum number of occupants	
Outside	1 person
Inside	2 people

Function Speed

Platform raise	40 to 50 seconds
Platform lower	50 to 60 seconds
High drive	
Platform lower than 2.1 to 2.4 m (7 to 8 feet)	3.2 km/h (0 to 2 mph)
Low drive	
Platform higher than 2.1 to 2.4 m (7 to 8 feet)	0.8 km/h (0 to 0.5 mph)

Drive System

Standard	Two wheel drive
Gradeability	25%
Maximum drive height	9.75 m (32')

Drive/Lift Level Sensor Interlock

Side-to-side	2 degrees
Front-to-rear	4 degrees

Tires

Nonmarking solid rubber 40.6 cm x 12.7 cm (16" x 5")

Electrical System

Voltage	24 V DC negative chassis ground
Source	Four - 6 V 240 amp hour batteries
Fluid recommended	distilled water
Charger	40 amp

Hydraulic System

Maximum pressure	21,373.75 kPa (3,100 psi)
Reservoir capacity	34 l (9 US gal)
System capacity	35 l (9.25 US gal)
Maximum operating temperature	71°C (160°F)
Hydraulic fluid recommended	
Above -13°C (10°F)	Mobil DTE-13M (ISO VG32)
Below -13°C (10°F)	Mobil DTE-11M (ISO VG15)

Ambient Air Temperature Operating Range

Celsius	-18°C to 43°C
Fahrenheit	0°F to 110°F

Maximum Wind Speed

Gust or steady	12.5 m/s (28 mph)
----------------	-------------------

Vibration

less than 2.5 m/sec²

Sound Threshold

below 70 dB(A)

Chapter 3 – Safety

Knowledge of the information in this manual, and proper training, provide a basis for safely operating the aerial platform. Know the location of all controls and how they operate to act quickly and responsibly in an emergency.

Safety devices reduce the likelihood of an accident. Never disable, modify, or ignore any safety device. Safety alerts in this manual indicate situations where accidents may occur.

If any malfunction, hazard or potentially unsafe condition relating to capacity, intended use, or safe operation is suspected, stop aerial platform operation and seek assistance.

The operator bears ultimate responsibility for following all manufacturer's instructions and warnings, regulations and safety rules of their employer and/or any state or federal law.

Electrocution Hazards

The aerial platform is made of metal components and is not insulated. Regard all conductors as energized. Do not operate outside during a thunderstorm.

Minimum Safe Approach Distance

Minimum safe approach distances to energized power lines and their associated parts must be observed while operating the aerial platform.

⚠ Danger

The aerial platform is not electrically insulated. Death or serious injury will result from contact with, or inadequate clearance from, an energized conductor. Do not go closer than the minimum safe approach distance as defined by ANSI or national safety regulations.

ANSI publications define minimum distances that must be observed when working near bus bars and energized power lines. Table 1 and Figure 4 are reprinted courtesy of Scaffold Industry Association, ANSI/SIA A92.6.

Voltage Range (Phase to Phase)	Minimum Safe Approach Distance	
	Feet	Meters
0 to 300V	Avoid Contact	
Over 300V to 50kV	10	3.05
Over 50kV to 200kV	15	4.60
Over 200kV to 350kV	20	6.10
Over 350kV to 500kV	25	7.62
Over 500kV to 750kV	35	10.67
Over 750kV to 1000kV	45	13.72

Table 1 – Minimum Safe Approach Distance

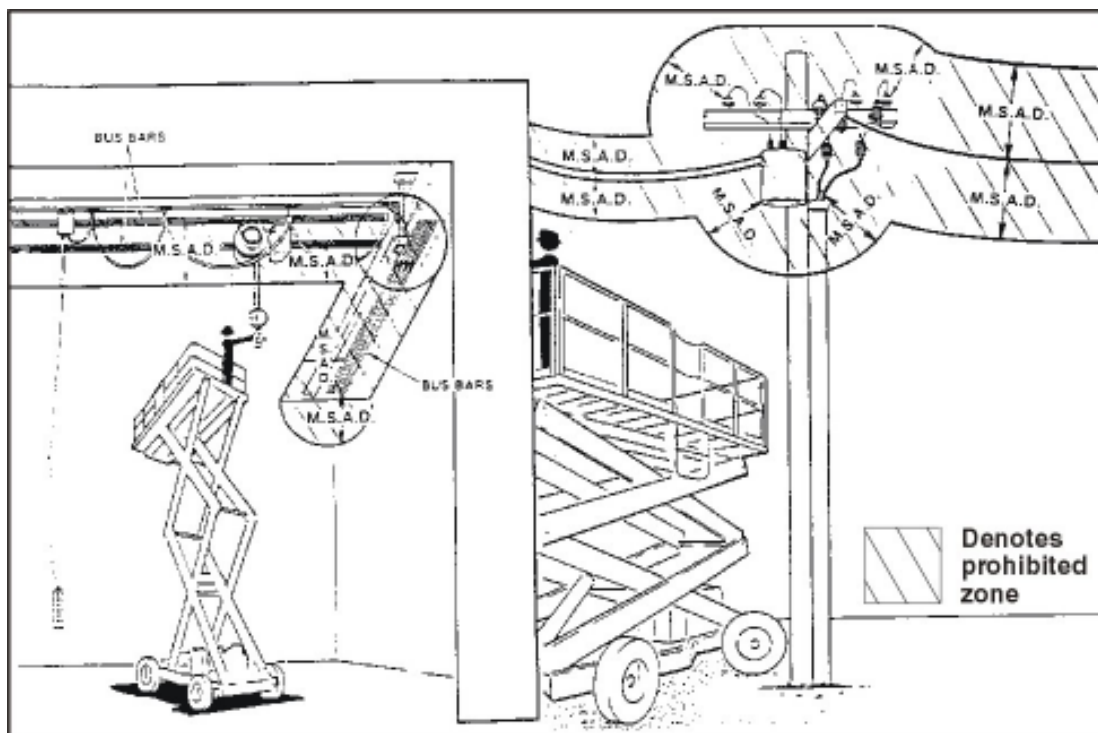

Figure 4 – Minimum Safe Approach Distance

Prestart Inspection

Perform a prestart inspection before each shift as described in Chapter 8. Do not use the aerial platform on the job unless you are trained and authorized to do so.

Work Place Inspection and Practices

Do not use the aerial platform as a ground connection when welding. The welding ground clamp must be attached to the same structure that is being welded. Electrical current flow can be very intense, causing serious internal damage to some components.

Inspect the area before and during aerial platform use. The following are some potential hazards that may be in the work place.

- Debris
- Slopes
- Drop-offs or holes
- Bumps and floor obstructions
- Overhead obstructions
- Unauthorized persons
- High voltage conductors
- Wind and weather conditions
- Inadequate surface and support to withstand load forces applied by the aerial platform in all operating configurations

Before using the aerial platform in any hazardous (classified) location, make certain it is approved and of the type required by ANSI/NFPA 505 for use in that particular location.

Know and understand the job site traffic-flow patterns and obey the flagmen, road signs, and signals.

While operating the aerial platform, a good safety practice is to have qualified personnel in the immediate work area to:

- Help in case of an emergency.
- Operate emergency controls as required.
- Watch for loss of control by platform operator.
- Warn the operator of any obstructions or hazards that may not be obvious to them.
- Watch for soft terrain, sloping surfaces, drop-offs, etc. where stability could be jeopardized.
- Watch for bystanders and never allow anyone to be under the platform, or to reach through the scissor arms while operating the aerial platform.

Danger

Pinch points may exist between moving components. Death or serious injury will result from becoming trapped between components, buildings, structures, or other obstacles. Make sure there is sufficient clearance around the machine before moving the chassis or platform. Allow sufficient room and time to stop movement to avoid contact with structures or other hazards.

Always look in the direction of movement. Drive with care and at speeds compatible with the work place conditions. Use caution when driving over rough ground, on slopes, and when turning. Do not engage in any form of horse-play or permit riders any place other than in the platform.

Secure all accessories, containers, tools, and other materials in the platform to prevent them from accidentally falling or being kicked off the platform. Remove all objects that do not belong in or on the aerial platform.

Never steady the platform by positioning it against another platform.

Do not operate the aerial platform if it is damaged or not functioning properly. Qualified maintenance personnel must correct the problem before putting the aerial platform back into service.

Operation

Use three points of support when entering or exiting the platform. For example, use two hands and one foot when climbing into the platform.

Make sure the area below the platform is free of personnel before lowering.

Keep both feet positioned firmly on the platform floor. Operate the controls slowly and deliberately to avoid jerky and erratic operation. Always stop the controls in neutral before going in the opposite direction.

Do not dismount while the aerial platform is in motion or jump off the platform.

Properly stow the aerial platform and secure it against unauthorized operation at the end of each work day, before transporting, or if it is left unattended.

Tip-Over and Falling Hazards

Operate the aerial platform only on a firm, flat, level surface capable of withstanding all load forces imposed by the aerial platform in all operating conditions. Refer to the General Specifications chart for the maximum wheel load, maximum floor pressure, and drive/lift level sensor interlock information. Raise the platform only when the aerial platform is on level ground.

Danger

The aerial platform can tip over if it becomes unstable. Death or serious injury will result from a tip-over accident. Do not drive or position the aerial platform for elevated use near any drop-off, hole, slope, soft or uneven ground, or other tip-over hazard. Do not raise the platform in wind speeds above 12.5 m/s (28 mph).

Do not operate the aerial platform within 1.2 m (4') of any drop-off or hole.

Do not raise the platform in winds above 12.5 m/s (28 mph).

Do not add anything to the aerial platform that will increase the wind loading such as billboards, banners, flags, etc.

Never operate the aerial platform without all parts of the guardrail system in place. Make sure the platform gate and the gravity gate are closed. Make sure that all protective guards, cowlings, and doors are securely fastened.

Do not exceed the platform capacity as indicated on the platform rating placard on the platform. Do not carry loads that extend beyond the platform guardrails without prior written consent from Snorkel.

Do not operate the aerial platform from trucks, trailers, railway cars, floating vessels, scaffolds, or similar equipment unless the application is approved in writing by Snorkel.

Do not use the aerial platform as a crane, hoist, jack, or for any purpose other than to position personnel, tools, and materials.

Do not climb on the guardrails or use ladders, planks, or other devices to extend or increase the work position from the platform.

Take care to prevent rope, electrical cords, and hoses, etc., from becoming caught in or on the aerial platform. If the platform or scissors structure becomes caught on an adjacent structure or other obstacle and is prevented from normal motion, reverse the control to free the platform. If control reversal does not free the platform, evacuate the platform before attempting to free it.

It is best not to transfer from the platform to another structure or from the structure to the platform, unless that is the safest way to do the job. Judge each situation separately taking the work environment into account. If it is necessary to transfer from the platform to another structure the following guidelines apply:

1. If you are using a fall restraint, transfer your anchorage from one structure to the other before stepping across.
2. Remember that you might be transferring to a structure where *personal fall arrest* is required.
3. Use the platform entrance, do not climb over or through the guardrails.

Electrical System

Charge the batteries in a well-ventilated area free of flame, sparks, or other hazards that might cause fire or explosion.

Do not operate any of the aerial platform functions while the battery charger is plugged in.

Warning

Batteries give off hydrogen and oxygen that can combine explosively. Death or serious injury could result from a chemical explosion. Do not smoke or permit open flames or sparks when checking the batteries.

Battery acid can damage the skin and eyes. Serious infection or reaction can result if medical treatment is not given immediately. Wear face and eye protection when working near the batteries.

Batteries contain sulfuric acid that can damage your eyes or skin on contact. Wear a face shield, rubber gloves, and protective clothing when working around batteries. If acid contacts your eyes, flush immediately with clear water and get medical attention. If acid contacts your skin, wash off immediately with clear water.

Hydraulic System

The hydraulic system contains hoses with hydraulic fluid under pressure.

Danger

Hydraulic fluid escaping under pressure can have enough force to inject fluid into the flesh. Serious infection or reaction will result if medical treatment is not given immediately. In case of injury by escaping hydraulic fluid, seek medical attention at once.

Do not place your hand or any part of your body in front of escaping hydraulic fluid. Use a piece of cardboard or wood to search for hydraulic leaks.

Placards and Decals

The aerial platform is equipped with placards and decals that provide instruction for operation and accident prevention. Do not operate the aerial platform if any placards or decals are missing or not legible.

Chapter 4 – Safety Devices

This aerial work platform is manufactured with safety devices, placards, and decals to reduce the likelihood of an accident. For the safety of all personnel, do not disable, modify, or ignore any safety device. Safety devices are included in the daily prestart inspection.

Warning

The potential for an accident increases when safety devices do not function properly. Death or serious injury can result from such accidents. Do not alter, disable, or override any safety device.

If any safety devices are defective, remove the aerial platform from service until qualified maintenance personnel can make repairs.

Emergency Stop Controls

There is an emergency stop control at the lower and upper controls.

At the lower controls, the emergency stop is a two-position push button (refer to Figure 4.1).



Figure 4.1 – Lower Controls

Push the emergency stop button in to disconnect power to all control circuits. Pull the button out to restore power.

Note

The lower controls override the upper controls. If the upper control emergency stop button is engaged, the lower controls can still be used to operate the aerial platform.

At the upper controls, the emergency stop is a two-position push button (refer to Figure 4.2).

Push the emergency stop button in to disconnect power to the upper control circuits. Pull the button out to restore power.

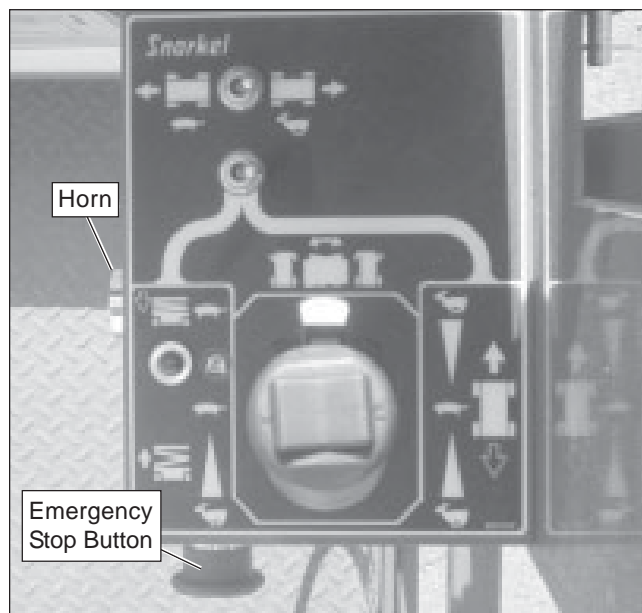

Figure 4.2 – Upper Controls

Drive Motion Alarm

When the joystick is moved out of neutral to drive the aerial platform, the alarm emits a loud beeping sound to warn personnel in the work area to stand clear.

Pothole Protector Skids

The pothole protector skids automatically lower when the platform is elevated approximately 61 cm (24"). Ground clearance is reduced from 10.1 cm (4") to 2.5 cm (1") when the skids lock into position (refer to Figure 4.3).

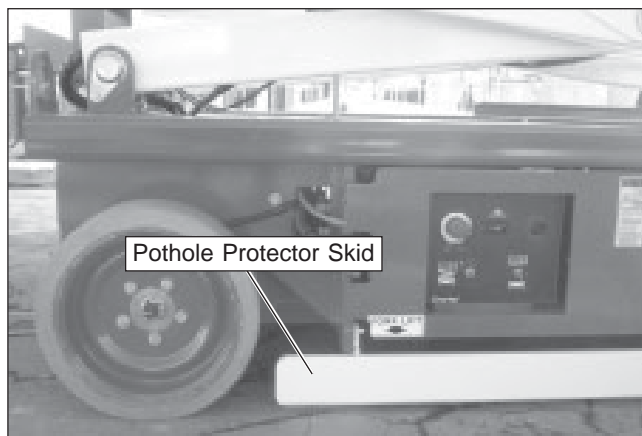

Figure 4.3 – Pothole Protector Skids

Danger

The aerial platform can tip over if it becomes unstable. Death or serious injury will result from a tip-over accident. Do not drive or position the aerial platform for elevated use within 1.2 m (4') of any drop-off, hole, or other tip-over hazard.

This protection system limits the tilt angle if a wheel is driven into a drop-off or hole. This greatly reduces the likelihood of the aerial platform tipping over.

The pothole protection system is for added protection and does not justify operating near drop-offs or holes.

Drive/Lift Pothole Protector Interlock

The aerial platform drive and lift functions are interlocked through a limit switch that senses whether or not the pothole protection linkage is locked into position. The drive/lift pothole interlock operates when the platform is elevated approximately 2.1 to 2.4 m (7 to 8 feet).

If an obstruction under the skids, or some other impairment prevents the skids from locking into position, the drive and lift functions will not operate and an alarm will sound.

Lower the platform and remove the obstruction when the drive/lift pothole protector interlock alarm sounds.

Drive/Lift Level Sensor Interlock

The aerial platform drive and lift functions are interlocked through a level sensor system. The drive/lift level sensor interlock operates when the platform is elevated approximately 2.1 to 2.4 m (7 to 8 feet).

If the chassis is tilted more than two degrees side-to-side or four degrees front-to-rear, the drive and lift functions will not operate and an alarm will sound.

Lower the platform and drive to a level surface when the drive/lift level sensor alarm sounds.

The drive/lift level sensor system is for added protection and does not justify operating on anything other than firm, flat, level surfaces.

Lowering Alarm

When the joystick is moved out of neutral to lower the platform, the alarm emits a loud beeping sound to warn personnel in the work area to stand clear.

Danger

Pinch points exist on the scissors structure. Death or serious injury will result if the scissors structure lowers onto personnel within the scissors arms or under the raised platform. Stand clear while raising and lowering the platform.

Be careful when lowering the platform. Keep hands and fingers away from the scissors structures components.

Lowering Interrupt

When the platform is lowered to about 1.5 m (5') lowering stops. The platform will not lower for five seconds regardless of the control position to allow personnel to clear the area of the scissors before the platform completely lowers.

Center the control in neutral to reset the lowering function, then continue to lower the platform.

Emergency Lowering Handle

The emergency lowering handle may be used to lower the platform if there is a malfunction in the hydraulic or electrical system. The handle is mounted at the rear of the aerial platform (refer to Figure 4.4).

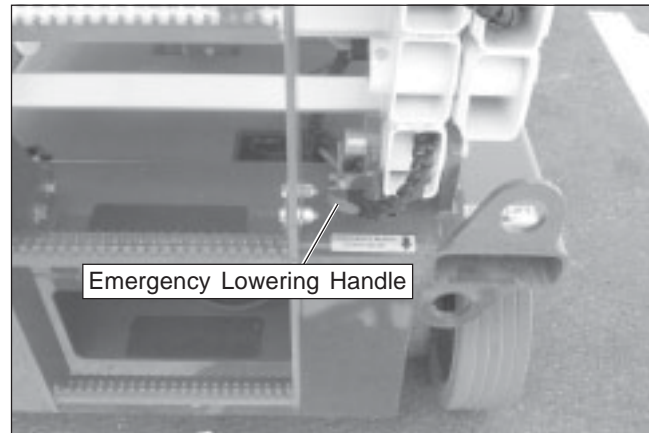

Figure 4.4 – Emergency Lowering Handle

The emergency lowering handle may be used to lower the scissors arms onto the safety prop before inspecting the machine. Pull the handle outward to lower the platform. Push the handle all the way back in after lowering the platform.

Safety Prop

The safety prop (refer to Figure 4.5) is used to support the scissors structure when access to the scissors arm components or the chassis is required. Always use the safety prop when the platform is raised during inspection and maintenance.



Figure 4.5 – Safety Prop

Guardrails

The guardrail system includes a top rail, mid rail, and toeboards around the sides of the platform (refer to Figure 4.6).

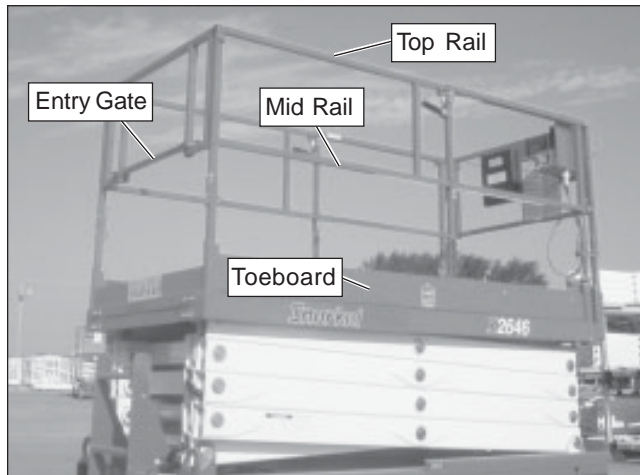

Figure 4.6 – Platform

An entry gate allows for access to the platform for loading work materials. The gate is part of the guardrail system and must be securely fastened after loading and entering the platform.

Horn

The horn may be used to warn personnel on the ground. The horn is operational when the machine is set up for operation from the upper controls.

Tilt Alarm

An alarm will sound if the aerial platform chassis is out of level more than two degrees side-to-side or four degrees front-to-rear when the platform is raised.

⚠ Danger

The aerial platform can tip over if it becomes unstable. Death or serious injury will result from a tip-over accident. Do not drive or position the aerial platform for elevated use near any drop-off, hole, slope, soft or uneven ground, or other tip-over hazard.

Completely lower the platform and then drive to a level surface when the tilt alarm sounds.

The tilt alarm is for added protection and does not justify operating on anything other than firm, flat, level surfaces.

Overload Protection

When the load in the platform is near or at rated capacity, an alarm will sound and the red light on the upper controls (refer to Figure 4.7) will flash.

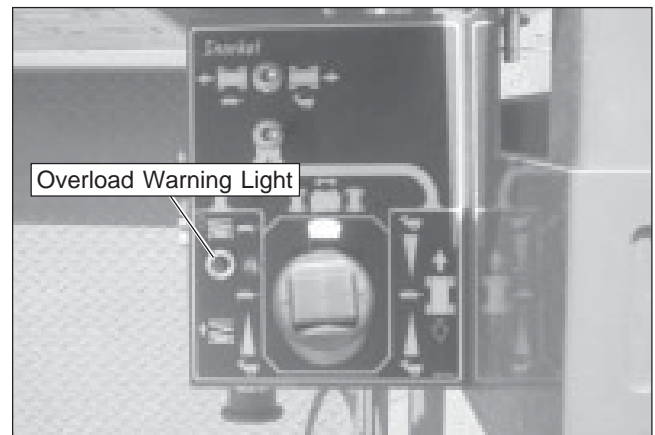

Figure 4.7 – Upper Controls

The alarm and light warn the operator that the platform is close to becoming overloaded. All functions remain fully operational.

⚠ Danger

The aerial platform can tip over if it becomes unstable. Death or serious injury will result from a tip-over accident. Do not exceed the capacity values indicated on the platform rating placard.

If the platform is fully lowered and is overloaded, when it is elevated just past 1.8 m (6'), a control module will stop the lift and drive functions and the alarm will sound and the warning light will flash. The platform can still be lowered to remove the excess load.

If the platform is elevated just past 1.8 m (6') and material is added to the platform overloading it, a control module will stop the lift, drive and lower functions and the alarm will sound and the warning light will flash. In this case, remove the load in excess of rated capacity and cycle the emergency stop button at the upper controls to return to normal operation.

Flashing Light

An optional red or amber flashing light may be located at the rear of the aerial platform. The flashing light warns personnel that the aerial platform is in the area.

The light flashes at about one flash per second when the machine is set up for operation from the upper controls.

Chapter 5 – Gauges and Displays

The aerial platform is equipped with several gauges to monitor the condition of the machine before and during operation.

Hour Meter

The hour meter is located on the lower control panel (refer to Figure 5.1). It measures the accumulated aerial platform operating time.

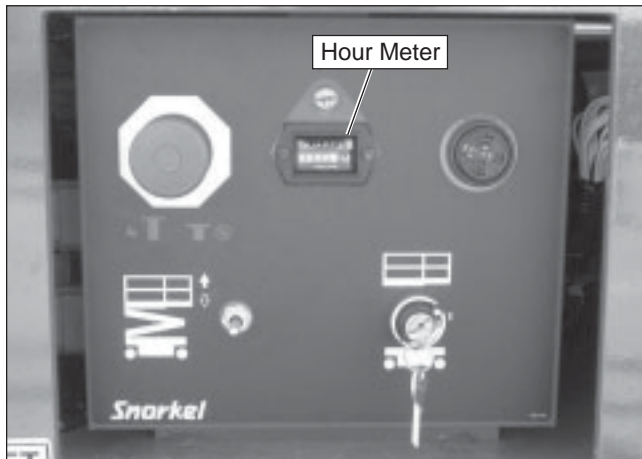

Figure 5.1 – Lower Controls

Ammeter

The ammeter is located on the battery charger (refer to Figure 5.2). When the batteries are charging, the ammeter displays the level of current flow from the charger to the batteries.

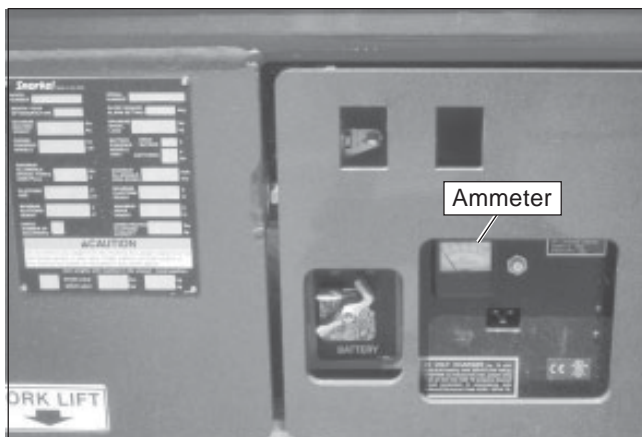

Figure 5.2 – Battery Charger

Battery Condition Indicator

The optional battery condition indicator (refer to Figure 5.3) is located on the upper control panel. It displays the level of available battery power to operate the aerial platform. The number one on the scale indicates full power and zero indicates no power.

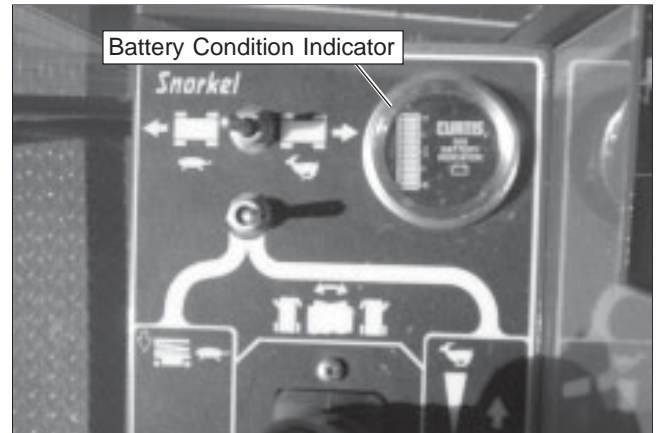

Figure 5.3 – Battery Condition Indicator

Chapter 6 – Batteries

The battery tray contains 4, 240 amp hour, 6 volt batteries. These batteries supply 24 volt DC electrical power to operate the aerial platform drive and platform control systems. Proper machine operation depends on well maintained and charged batteries.

General Maintenance

Always keep the batteries clean, free of dirt and corrosion. A film on top of the battery can accelerate discharge.

Cold reduces battery capacity and retards charging. Heat increases water usage and can result in overcharging. Very high temperatures can cause thermal run away which may lead to an explosion or fire. Consult a battery charger specialist if extreme temperature use is unavoidable.

⚠ Warning

Battery acid can damage the skin and eyes. Serious infection or reaction can result if medical treatment is not given immediately. Wear face and eye protection when working near the batteries.

Use distilled water to refill the batteries. Avoid water containing metallic solids such as iron.

Charging

Fully recharge the batteries, immediately after use. One charging cycle per day is preferred. Fully charged batteries perform best. The deeper the discharge, the fewer number of cycles a battery will deliver. Deep discharges deteriorate the battery quicker than light shallow cycles.

An overly discharged battery may need to be cycled a few times before it can fully recover. If a battery begins to heat before becoming fully charged, it may be necessary to recharge and discharge the battery a few times.

The aerial platform is equipped with an automatic battery charger that will completely recharge the batteries and turn off after the charge cycle is completed.

⚠ Warning

Batteries give off hydrogen and oxygen that can combine explosively. Death or serious injury can result from a chemical explosion. Charge the batteries only in a well ventilated area away from sparks or flame.

⚠ Caution

The batteries can be overcharged and/or damaged if the charger fails to shut off automatically. Do not leave the battery charger on for more than two days.

It may take from 1 1/2 to 16 hours to recharge the batteries depending on the amount of discharge. If the charging cycle exceeds 16 hours without the batteries being fully recharged, shut off the charger and have the batteries checked.

Use the following procedure to charge the batteries.

1. Turn the battery disconnect switch off (refer to Figure 6.1). The switch is next to the latch on the battery tray.

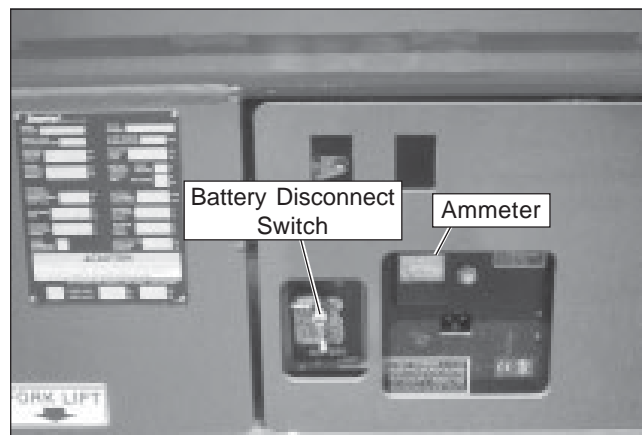

Figure 6.1 – Battery Tray

2. Check the battery water level. Add water to individual cells only if the plates are exposed. Replace the battery caps.
3. Plug the charger into a properly grounded AC outlet using a 3 conductor, 14 gauge or larger extension cord. The extension cord must be as short as possible and in good electrical condition. Make sure the AC voltage selector switch on the charger is set to the same voltage as the outlet voltage. The charger will turn on three to five seconds after a complete electrical connection is made. The ammeter (refer to Figure 6.1) will indicate near 40 amps initially then taper off to 5 to 10 amps as the batteries charge.

Note

If the batteries are fully charged when the charger is plugged in, the ammeter will initially read 35 to 40 amps then quickly read zero.

4. Leave the charger plugged in until it shuts itself off.
5. Unplug the extension cord after the battery charger turns itself off. Allow the batteries to cool off after charging.
6. Check the battery water level. Add water to individual cells only if the plates are exposed. Replace the battery caps.

Chapter 7 – Controls

⚠ Danger

Pinch points may exist between moving components. Death or serious injury can result from becoming trapped between components, buildings, structures, or other obstacles. Make sure all personnel stand clear while operating the aerial platform.

Controls to position the platform are located on the lower control panel on the chassis and on the upper control panel in the platform. Drive controls are located on the upper control panel only.

Battery Disconnect Switch

The battery disconnect is located next to the latch on the battery tray (refer to Figure 7.1).

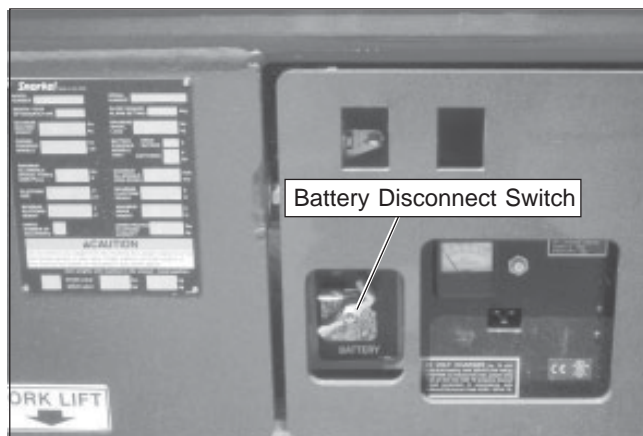

Figure 7.1 – Battery Disconnect Switch

The battery disconnect switch removes electrical power from all electrically controlled functions when in the off position. Place the switch in the on position to operate any electrically controlled function.

⚠ Caution

Only authorized personnel should operate the aerial platform. Unqualified personnel may cause injury to coworkers or property damage. Lock the battery disconnect switch in the off position before leaving the aerial platform unattended.

Lock the battery disconnect switch in the off position to prevent unauthorized use of the aerial platform.

Lower Controls

The lower controls (refer to Figure 7.2) are located on the right side of the chassis. Only platform functions can be operated from the lower controls. The following controls are located on the lower control panel.

- Emergency stop button
- Control selector switch
- Platform raise/lower switch

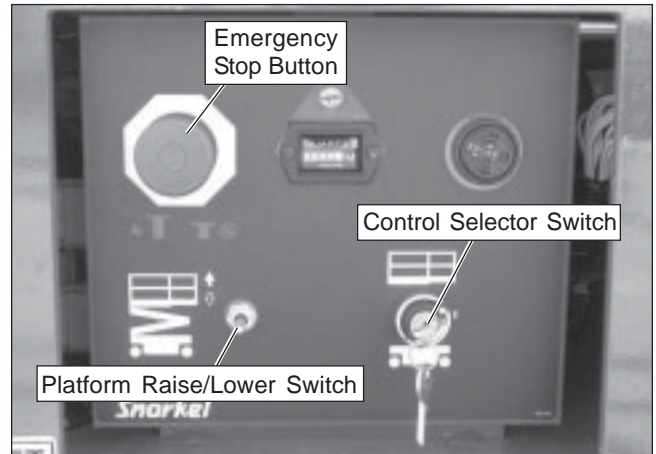

Figure 7.2 – Lower Controls

Emergency Stop Button

The emergency stop is a two-position push button. Push the button in to disconnect power to all control circuits. Pull the button out to restore power.

Control Selector Switch

Insert the key into the control selector switch. Turn the switch to the lower controls position to operate aerial platform functions from the lower controls. The upper controls will not operate while the control selector is in the lower position.

Turn the switch to the upper controls position to operate the aerial platform functions from the upper controls.

In the center position, aerial platform functions will not operate from the lower or upper controls.

Platform Raise/Lower Switch

Pull up on the platform switch toward the white arrow to raise the platform. Release the switch when the desired height is reached.

Push down on the switch toward the black arrow to lower the platform. The lowering alarm will sound as the platform lowers.

Upper Controls

The upper controls (refer to Figure 7.3) are located on the control box at the platform. The following controls are located at the upper control station.

- Emergency stop button
- Drive/lift selector switch
- Drive range switch
- Joystick to control platform lift, drive and steer

The horn button and battery condition indicator gauge may also be located at the upper control station.

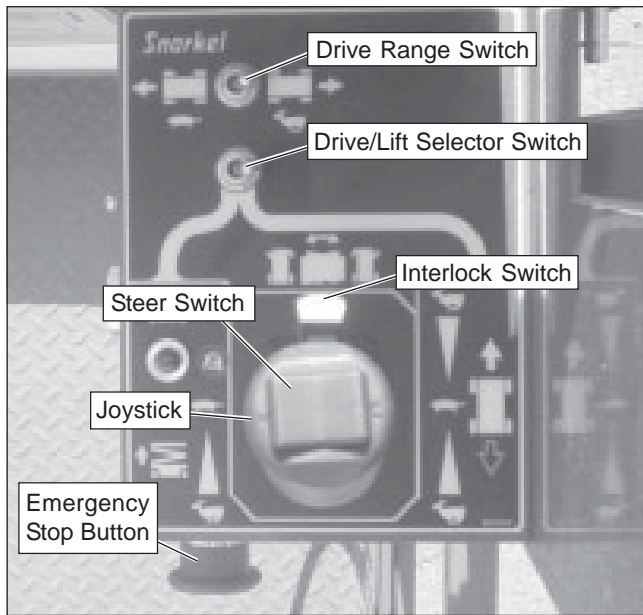

Figure 7.3 – Upper Controls

Emergency Stop Button

The emergency stop is a two-position red push button on the front of the upper control box. Push the button in to disconnect power to all control circuits at the upper controls. Pull the button out to restore power.

Note

The lower controls override the upper controls. If the upper control emergency stop is engaged the lower controls can still be used to operate the aerial platform.

Push the button in when the upper controls are not in use to help protect against unintentional platform operation.

Drive/Lift Selector Switch

Place the drive/lift selector switch in the drive position to drive the aerial platform using the joystick. The platform will not raise or lower while driving.

Place the drive/lift selector switch in the lift position to raise and lower the platform using the joystick.

Joystick

Use the joystick (refer to Figure 7.3) to operate the following functions.

- Aerial platform steering
- Aerial platform drive and speed
- Platform raise/lower and speed

Movement of the joystick in a given direction produces a corresponding movement of the aerial platform. The steering and drive functions may be operated separately or simultaneously.

Interlock

The joystick has an interlock switch in the handle. Engage the interlock by grasping the joystick and pulling the switch toward the handle. Engage the interlock to activate the steering, drive, or lift functions.

Steer Switch

The steer switch is a momentary contact, rocker switch on top of the joystick. This switch controls the two front wheels to steer the aerial platform.

To steer to the right, engage the interlock on the joystick and hold down the right side of the steer switch. To steer to the left, engage the interlock on the joystick and hold down the left side of the steer switch.

Note

The steering wheels are not self-centering. Set the steering wheels straight ahead after completing a turn.

Drive Range Switch

The drive range switch has two positions to select drive wheel operation:

- High (Rabbit) – for normal driving conditions.
- Low (Turtle) – for driving on grades up to 25 percent that require low speed and high torque operation, where high range is not sufficient to climb the grade.

Horn Button

The horn button is on the left side of the upper control box. Press the button to sound the horn.

Battery Condition Indicator

The optional battery condition indicator gauge is on the top of the upper control box. It indicates the level of available battery power to operate the aerial platform.

Chapter 8 – Prestart Inspection

Potential service and safety problems may be detected by inspecting the aerial platform. This chapter includes information on properly inspecting the aerial platform and includes a prestart inspection check list at the end of the chapter to ensure that no areas are overlooked.

Warning

The potential for an accident increases when operating an aerial platform that is damaged or malfunctioning. Death or serious injury can result from such accidents. Do not operate the aerial platform if it is damaged or malfunctioning.

Perform a prestart inspection at the beginning of each shift, before using the aerial platform on the job. The inspection site must have a smooth and level surface.

Operator's Manual

The manual holder is located in the platform (refer to Figure 8.1) at the front of the machine. Make certain it is securely fastened in place.

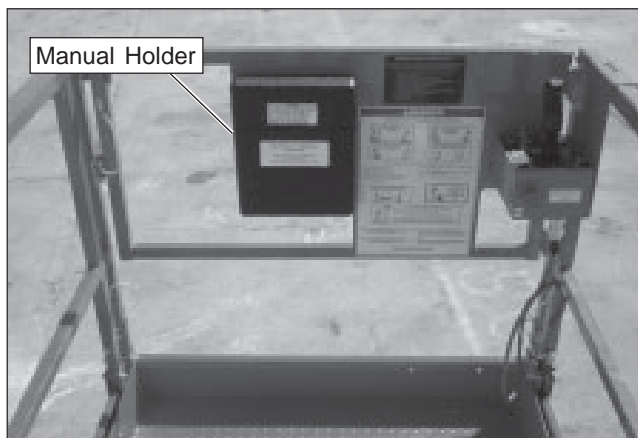

Figure 8.1 – Operator's Manual Holder

Check to see that the proper Operator's Manual is in the holder. The manual should be complete with all pages intact and in readable condition.

Electrical System

Electrical power is supplied from 4, 240 amp hour, 6 volt batteries. These batteries supply 24 volt DC electrical power to operate the aerial platform drive and control system.

Warning

Batteries give off hydrogen and oxygen that can combine explosively. Death or serious injury can result from a chemical explosion. Do not smoke or permit open flames or sparks when checking the batteries.

Caution

Even with low voltage electrical systems, severe arcing can occur. Electrical shock or component damage can result from contact with energized conductors. Use caution when working with any electrical device.

The batteries are in the swing-out tray on the left side of the aerial platform.

Battery Fluid Level

Remove the caps from each battery (refer to Figure 8.2). Visually check the battery fluid level. If the level is not within 0.6 cm (1/4") of the bottom of the filler neck inside each hole, add distilled water.

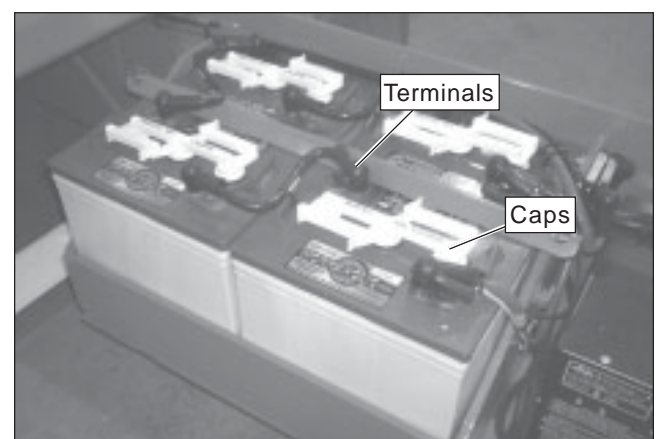

Figure 8.2 – Batteries

Replace the caps on the batteries. The caps must be in place and tight during machine operation and battery charging.

Battery Terminals

Check the top of the batteries, the terminals, and cable ends (refer to Figure 8.2). They should be clean and free of corrosion and dirt. Clean the top of the batteries if necessary. Clean the terminals and cable ends with a wire brush or terminal cleaning tool. All cable ends must be securely fastened to the terminals.

Battery Charger

Inspect the battery charger (refer to Figure 8.3) to ensure that it is operating properly.

1. Turn the battery disconnect switch off.
2. Plug the charger into a source of power.
3. Observe the reading on the ammeter. The reading should be 40 amps.

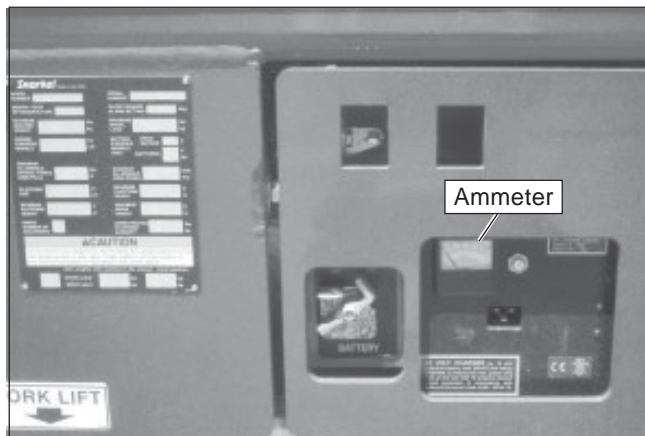

Figure 8.3 – Battery Charger

4. Unplug the charger.

Safety Prop

Using the lower controls, raise the platform until the open height between the arm pins is wide enough to position the safety prop. Refer to Figure 8.4.



Figure 8.4 – Safety Prop

Swing the safety prop downward from the storage position to the support position. Inspect the safety prop for damage and deformation.

Always use the safety prop when the platform is raised during inspection and maintenance.

⚠ Danger

Pinch points exist on the scissors structure. Death or serious injury will result if the scissors structure drops onto personnel working within the scissor arms or under the raised platform. Properly position the safety prop before reaching through the scissors structure.

When inspecting or servicing the aerial platform with the platform raised, use the following procedure to properly position the safety prop.

1. Remove all tools and material from the platform.
2. Using the lower controls, raise the platform until the open height between the arm pins is wide enough to position the safety prop. Refer to Figure 8.4.
3. Swing the safety prop downward from the storage position to the support position.
4. Remove hands and arms from the scissor structure area.
5. Lower the platform until the scissor structure is supported by the safety prop.

Use the following procedure to stow the safety prop.

1. Using the lower controls, raise the platform until the open height between the arm pins is wide enough to move the safety prop.
2. Swing the safety prop up to the stowed position.

Cables and Wiring Harness

Inspect all cables and wiring for wear and/or physical damage such as loose connections, broken wires, and frayed insulation. Check the wiring in areas where a change in routing direction may cause them to become pinched (refer to Figure 8.5). Make sure the cables and wires are properly routed to avoid sharp edges, pinching, and scuffing.

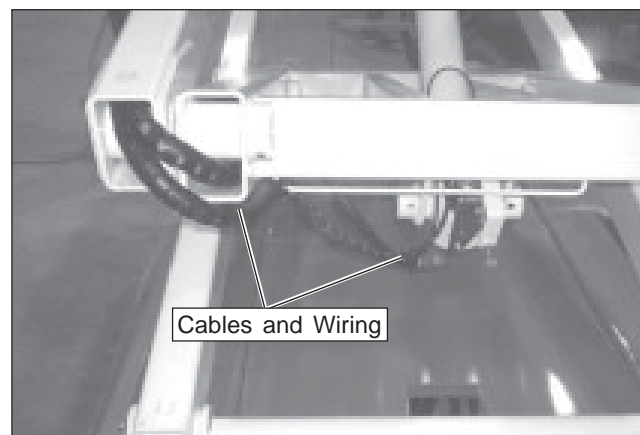

Figure 8.5 – Cables and Wiring Harness

Hydraulic System

Hydraulic power is supplied from a two section hydraulic pump with a 7 horsepower DC electrical motor.

⚠ Danger

Hydraulic fluid escaping under pressure can have enough force to inject fluid into the flesh. Serious infection or reaction will result if medical treatment is not given immediately. In case of injury by escaping hydraulic fluid, seek medical attention at once.

The hydraulic reservoir, pump, filter, and control valve are located in the hydraulic tray on the right side of the chassis.

Fluid Level

Check the hydraulic fluid level with the aerial platform on a level surface and the platform stowed. The fluid level must be between the add and full marks (refer to Figure 8.6).

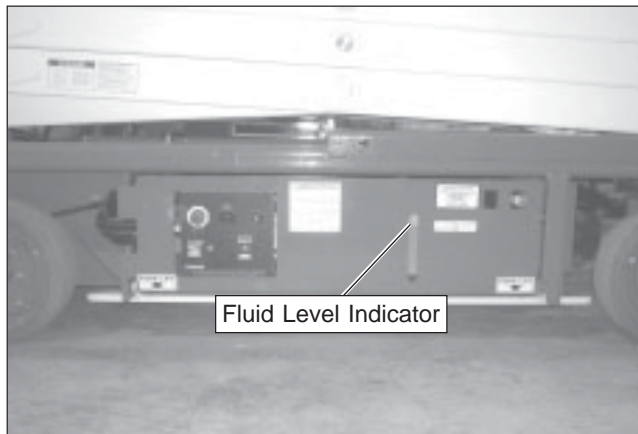

Figure 8.6 – Hydraulic Tray

⚠ Caution

Not all hydraulic fluid is suitable to use in the hydraulic system. Some have poor lubricating characteristics and can increase component wear. Only use hydraulic fluid as recommended.

If necessary, remove the filler cap and add fluid of the proper type. Refer to Chapter 2 – Specifications for the proper type and grade of hydraulic fluid to use. The need to regularly add fluid indicates a leak that should be corrected.

Hoses and Fittings

Inspect all hydraulic hoses and fittings for wear, leakage, or damage (refer to Figure 8.7). Make sure the hoses are properly routed to avoid sharp edges, kinking, and scuffing. Make sure all hoses are held firmly in their support brackets.



Figure 8.7 – Hoses and Fittings

Hydraulic fluid leaks are easily visible on the ground. Check under the chassis for fluid that has leaked.

Free-Wheeling Valve

The free-wheeling valve is located on the drive valve at the rear of the machine (refer to Figure 8.8). Check the free-wheeling valve to make sure it is fully closed (clockwise).

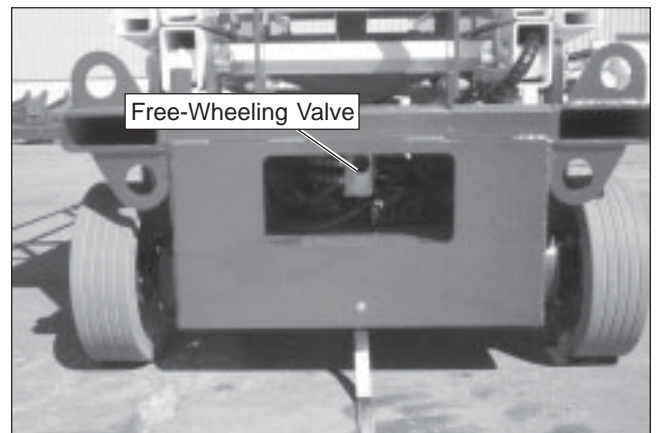

Figure 8.8 – Free-Wheeling Valve

Tires and Wheels

Visually inspect the tires (refer to Figure 8.9). They should be smooth without any cuts, gouges, or missing rubber that might affect aerial platform stability.



Figure 8.9 – Tires and Wheels

Check the wheel lug nuts to see that none are missing, damaged, or loose.

Ground Strap

Make certain the ground strap (refer to Figure 8.10) is securely fastened to the chassis. It should be long enough to contact the ground surface to eliminate static electricity from the machine.

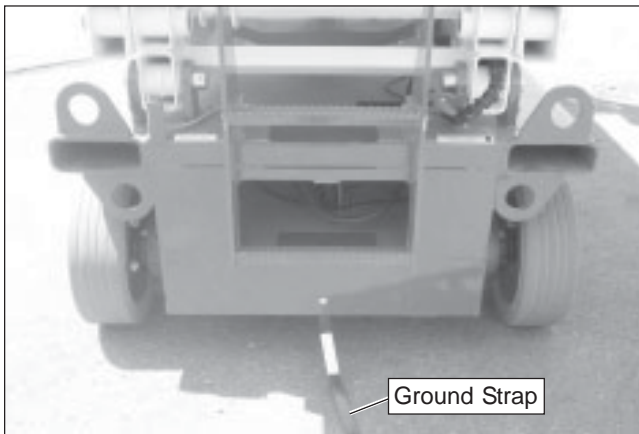

Figure 8.10 – Rear of Chassis

Lower Control Station

With no personnel in the platform, test the operation of each control from the lower control station (refer to Figure 8.11).

Operating Controls

Use the following procedure to operate the machine from the lower controls.

1. Turn the battery disconnect switch on.

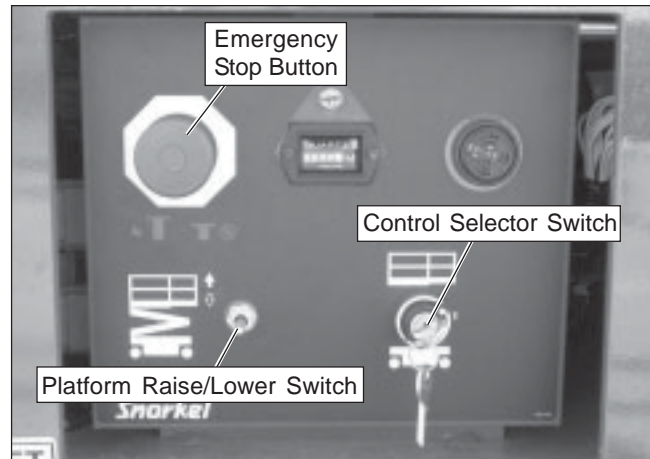

Figure 8.11 – Lower Controls

2. At the lower controls, pull the emergency stop switch outward to the on position.
3. Insert the key into the control selector switch and turn the switch to the lower controls position.

⚠ Danger

Pinch points may exist between moving components. Death or serious injury will result from becoming trapped between components, buildings, structures, or other obstacles. Make sure all personnel stand clear of the aerial platform while performing the prestart inspection.

Test the operation of the platform raise/lower switch in both directions.

Place the battery disconnect switch in the off position. The platform should not raise or lower with the disconnect in this position.

Emergency Stop

Push the emergency stop button in to turn off the electrical power. The lower control functions should not operate with the emergency stop in this position.

Lowering Alarm and Interrupt

Raise the platform approximately 3 m (10'). Lower the platform and make sure the alarm sounds. The platform should stop lowering when it reaches about 1.5 m (5'). Release the raise/lower toggle switch to reset the lowering function. Wait for 5 seconds and then push the joystick forward to continue lowering.

Pothole Protector Interlock

Perform this test using the lower controls.

1. Stow the aerial platform on a smooth, flat, level concrete slab.
2. Remove all persons and materials from the platform.

3. With the trays closed, check the ground clearance under the pothole protector skids (refer to Figure 8.12). Clearance should be at about 10.1 cm (4") on both sides of the aerial platform.

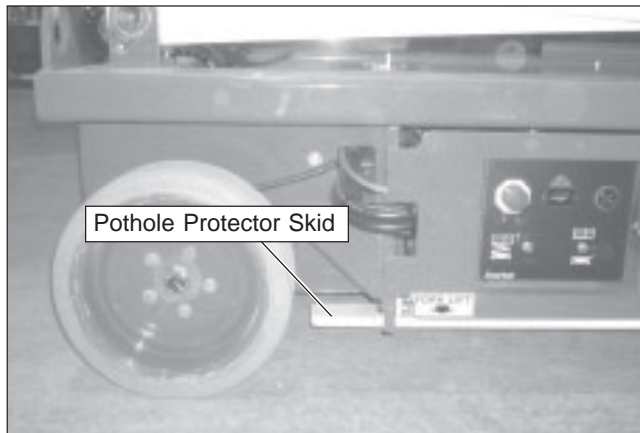

Figure 8.12 – Pothole Protector Skid

4. Raise the platform while watching movement of the skids. The skids should lower to approximately 2.5 cm (1") ground clearance when the platform is raised approximately 61 cm (24").
5. Fully lower the platform while watching movement of the skids. The skids should raise to their stowed position, with about 10.1 cm (4") ground clearance, when the platform is fully lowered.
6. Place a 3.8 cm (1 1/2") thick board, such as a 2 x 4, under the skid on the left side (refer to Figure 8.13).

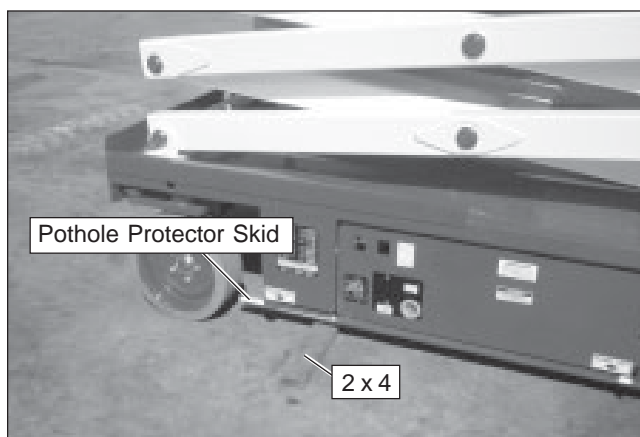

Figure 8.13 – Pothole Protector Interlock Test

7. The board will prevent the skid from lowering fully. Raise the platform. When the skid contacts the board, the platform should stop raising and an alarm should sound at approximately 2.1 to 2.4 m (7 to 8 feet) platform floor height. The alarm should then sound when the platform lift switch is activated and the platform should not raise.

8. Lower the platform. Place the board under the skid on the right side.
9. Raise the platform. When the skid contacts the board, the platform should stop raising and an alarm should sound at approximately 2.1 to 2.4 m (7 to 8 feet) platform floor height. The alarm should then sound when the platform raise switch is activated and the platform should not raise.

⚠ Warning

The potential for an accident increases when safety devices do not function properly. Death or serious injury can result from such accidents. Do not alter, disable, or override any safety device.

10. If the platform raise function is not disabled, or the alarm does not sound remove the aerial platform from service until the problem is corrected.

Emergency Lowering

Using the lower controls, fully raise the platform. Locate the emergency lowering handle (refer to Figure 8.14) at the rear of the aerial platform.

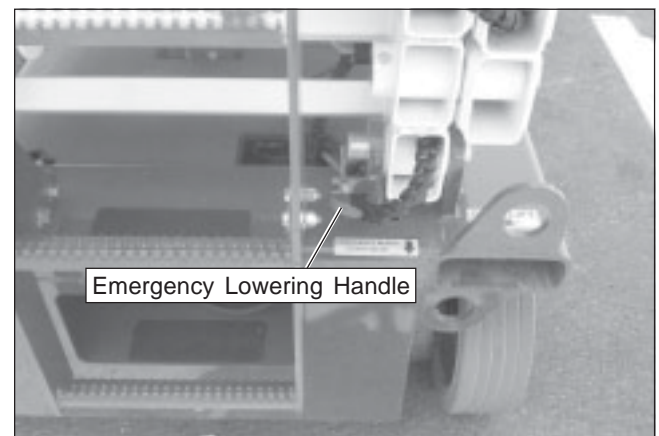

Figure 8.14 – Rear of Chassis

While standing clear of the scissors structure, pull the handle out and the platform will begin to lower. Push the handle in to stop. Make certain the handle is all the way back in after lowering the platform.

Structures

Visually inspect all mechanical structures including the weldments and related components. It is important to inspect the fasteners that connect the components.

Weldments

Visually inspect all weldments for abnormal wear, abrasion, or deformation that could cause interference between moving parts.

Inspect the welds on the structural components. The area to be inspected should be clean and free of dirt and grease.

Look for visible cracks in the weld and at the weld to parent material joint. A bright light may be used to provide adequate visibility of the inspection area.

Pay close attention to welds in areas where changes in cross section take place and near the attachment points of highly loaded components.

Slide Pads

Visually inspect the scissors arm slide pads (refer to Figure 8.15). The slide pads must be free to move without obstruction. There is one slide pad on each side of the chassis.

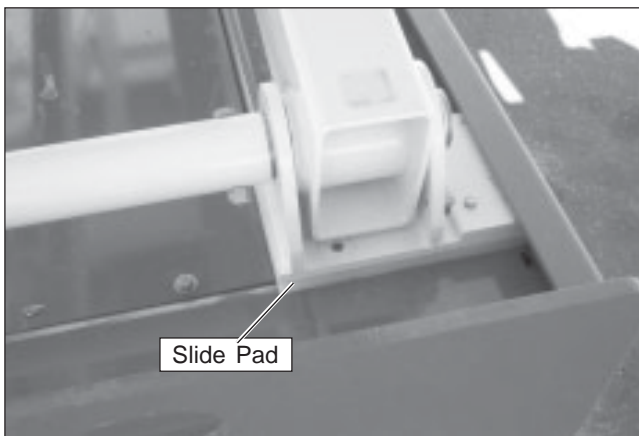

Figure 8.15 – Scissors Arm Slide Pads

Raise the platform from the lower controls to visually inspect the slide pads underneath the front of the platform (refer to Figure 8.16).



Figure 8.16 – Platform Slide Pads

There is one slide pad on each side of the platform. The slide pads must be in good condition and free to move without obstruction.

Fasteners

Visually inspect all fasteners to see that none are missing or loose.

Pay particular attention to all of the bolts, nuts, roll pins, collars, and snap rings that connect the scissors arms. They should all be present, tight, and not damaged in any way.

Upper Control Station

Inspect the platform and upper controls only if all functions operated properly from the lower controls.

Guardrail System

The guardrail system (refer to Figure 8.17) includes the top rail, mid rail, toeboards, and the entry gate.

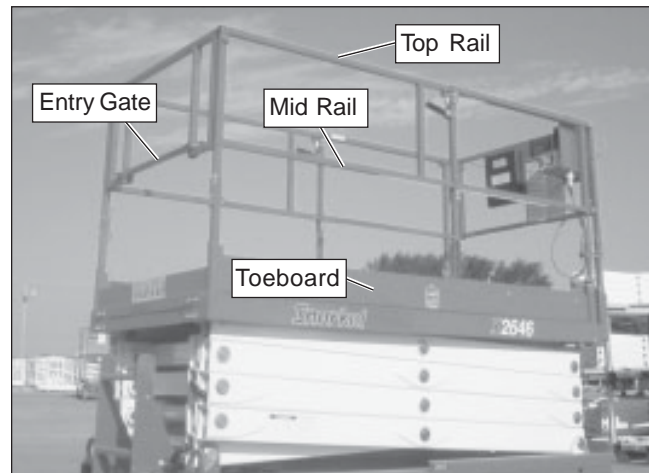

Figure 8.17 – Guardrail System

Inspect all components of the guardrail system. The rails and toeboards must all be in place and free of any damage or deformation. Visually check the rail and toeboard welds for cracks. All bolts, nuts and pins fastening the guardrails in place must be present and not show any signs of looseness.

Inspect the entry gate to be sure that it is securely pinned in place and is not deformed in any way. Inspect the safety chain to be sure it is present and securely fastened to the gate. The chain, and the hook and eye that secures it to the gate, must be free of damage and deformation that may prevent it from functioning properly. Inspect the pin that secures the gate to the rail. Make sure the gate is secure when it is closed.

Platform Extension

A pin on each side of the platform secures the extension deck to the main platform deck. The pin is connected to a handle mechanism to release the extension deck.

Caution

The extension deck is free to move when the pins are disengaged. Make certain the pin is engaged when the deck is extended in the working position and when it is stowed.

Inspect the handles and pins (refer to Figure 8.18) to ensure that they operated properly and secure the extension deck. Hold the handles downward to release the pins and to extend the platform. Extend the platform while checking for proper operation.

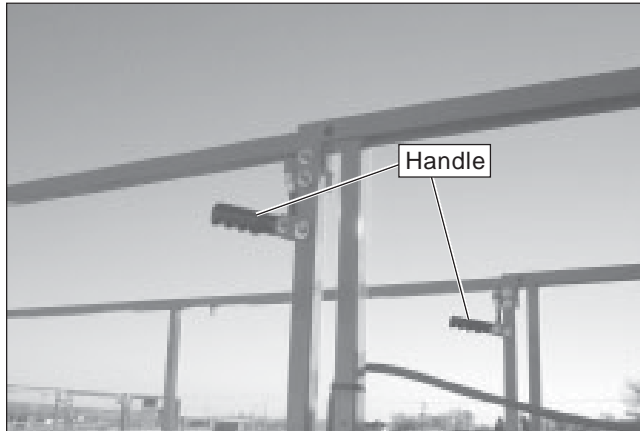

Figure 8.18 – Platform Extension Handle

Extend the platform and inspect the weldments for deformation and damage. Visually check the platform welds for cracks.

Swing-Down Rails

Inspect the pins that hold the rails in position (refer to Figure 8.19) to make sure they are in place and are not deformed. There is one pin on each vertical side rail, the entry gate, the front panel and one that fastens the upper controls to the platform rails.

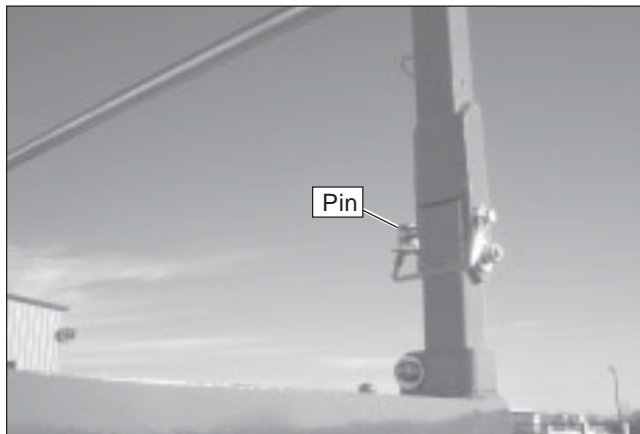

Figure 8.19 – Swing-Down Rails Pin

Brakes

Test the operation of the brakes while operating the aerial platform from the upper controls.

The brakes are engaged when:

- the joystick interlock is released.
- the drive/lift selector switch is in the lift position.
- the emergency stop button is pushed down.

Placing the drive/lift selector in the drive position, engaging the interlock and moving the joystick, releases the brakes.

Operating Controls

With the aerial platform stowed, test the operation of each control from the upper control station (refer to Figure 8.20).

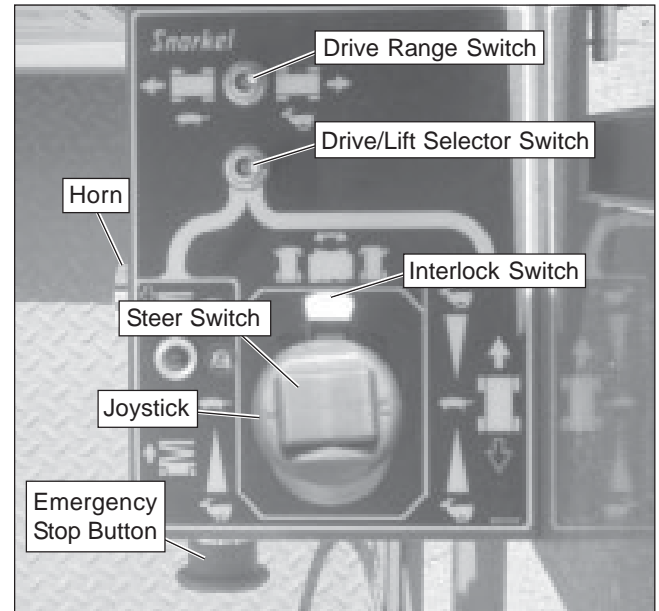

Figure 8.20 – Upper Controls

Place the battery disconnect switch in the on position and from the lower controls, place the control selector upward in the upper controls position. Pull the emergency stop button outward to turn on the electrical power to the upper controls.

From the upper controls, test the interlock by moving the joystick without engaging the interlock switch. If movement occurs the interlock is not functioning properly. Do not operate the machine until the problem is corrected.

Place the drive/lift selector switch in the drive position and test the operation of the joystick in both directions. The lift functions should not operate with the selector in the drive position.

Place the drive/lift selector switch in the lift position and test the operation of the joystick in both directions. The drive functions should not operate with the selector in the lift position.

Emergency Stop

Push the emergency stop button in to turn off the electrical power. The upper control functions should not operate with the emergency stop in this position.

Horn

Press the horn button to ensure that the horn operates properly.

Lowering Alarm and Interrupt

Raise the platform approximately 3 m (10'). Push the joystick forward to lower the platform. The platform should stop lowering when it reaches about 1.5 m (5'). Center the joystick in neutral to reset the lowering function. Wait for 5 seconds and then push the joystick forward to continue lowering.

Drive Motion Alarm

Drive in both the forward and reverse directions to ensure that the alarm sounds to warn personnel in the area that the aerial platform is in motion.

Flashing Light

If the machine is equipped with the optional flashing light, visually check to see that it flashes. The light should flash when power is turned on to operate the machine.

Battery Condition Indicator

The optional battery condition indicator (refer to Figure 8.21) is located on the upper control panel.

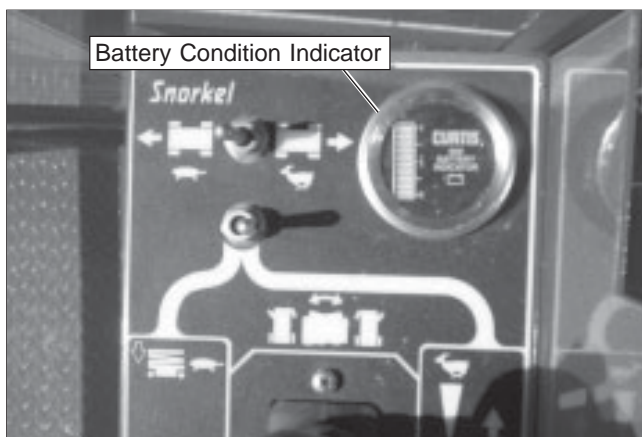

Figure 8.21 – Electrical Power Outlet

With the machine set up to operate from the upper controls, check to see that the battery condition indicator gauge displays a power reading.

Placards and Decals

Inspect all safety and operational placards and decals. Make certain they are in place, in good condition, and are legible. The placards and decals may be cleaned with soap and water, and a soft cloth if the words or pictures cannot be seen.

Caution

Solvents may contain hazardous ingredients. Follow the manufacturer's label for proper use and disposal. Wear protective gloves and splash-proof safety glasses when using solvents.

Wet paint overspray may be removed using a natural biodegradable solvent and a soft cloth. Replace any missing or illegible placards or decals before operating the aerial platform. Placard and decal kits are available from Snorkel.

The safety related placards and decals are illustrated on the following pages.

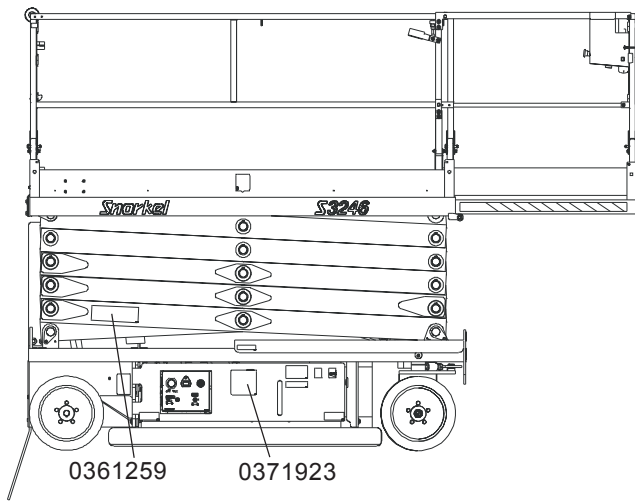

Right Side

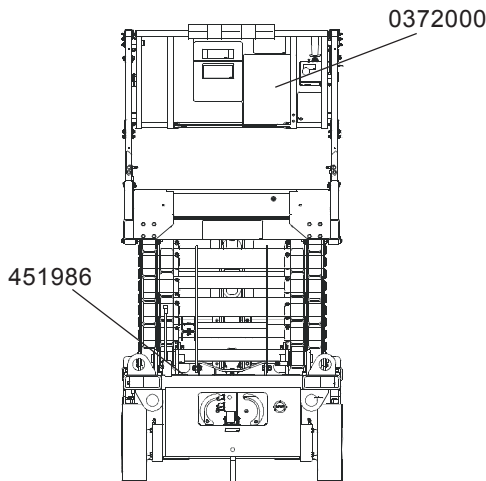

Rear

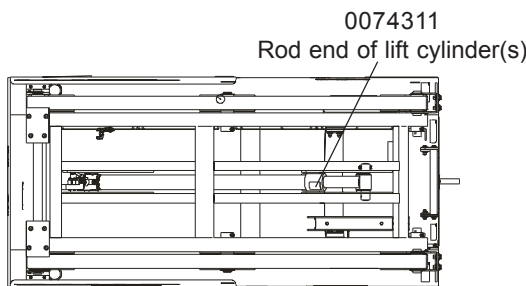

Top of Chassis

▲ DANGER

Proper position for safety prop use

Death or serious injury might result if safety prop is not used and/or properly positioned. Use safety prop at all times when servicing machine with platform raised.

PROPER USE OF SAFETY PROP

1. Remove all material from platform.
2. Raise platform until the open height is wide enough to position the safety prop.
3. Place safety prop in the proper position.
4. Remove hands and arms from scissors area.
5. Lower platform until scissors are supported by safety prop.

TO STORE SAFETY PROP

1. Raise platform until the open height is wide enough to position the safety prop.
2. Place the safety prop in the storage position.

0361259

▲ WARNING

DEATH OR SERIOUS INJURY MAY RESULT FROM UNCONTROLLED MOTION

Towing this machine requires releasing the brakes. Follow instructions below when towing this machine. Verify the brakes have been reset after towing and before operating the machine.

TOWING INSTRUCTIONS

1. Before towing, pushing or moving machine away to an level ground with wheels checked. Read and understand all instructions. Refer to Operator's Manual. Turn battery disconnect switch to "OFF" position.
2. Push and release the hand pump several times to disengage the rear wheel disc brakes.
3. Rotate free-wheeling valve clockwise/counter-clockwise as shown. Free-wheeling valve is located at the rear of machine.
4. DO NOT exceed 3.2 km (2 mph) when towing.
5. After moving machine, close the free-wheeling valve, and verify that brakes reset after operating drive. If brakes do not reset, refer to the Troubleshooting chapter in the Operator's Manual.

DISCONNECT BRAKES

DO NOT operate any hydraulic functions after disengaging the brakes. This will reset the brakes, preventing the machine from being towed.

Hand pump located on main control valve in the hydraulic tray

PROHIBITED VALVE

0371923

▲ DANGER

DEATH OR SERIOUS INJURY CAN RESULT FROM TIPPING OVER. TO KEEP FROM TIPPING THIS MACHINE OVER FOLLOW THESE RULES.

DO NOT RAISE OR DRIVE AN ELEVATED PLATFORM ON A SLOPE

DO NOT CLOSER THAN 4 feet (1.2m) TO ANY DROPOFF OR HOLE

DO NOT RAISE OR DRIVE AN ELEVATED PLATFORM ON SOFT OR UNEVEN SURFACES

DO NOT RAISE THE PLATFORM IN WIND ABOVE 23 MPH (12.14 M/S)

OTHER ACTIONS CAN ALSO CAUSE THIS MACHINE TO TIP OVER

DO NOT overload safety devices.
DO NOT stand or sit on guardrails.
DO NOT attach ropes or chains to guardrails.
DO NOT carry loads outside the rating or use as a crane.

DO NOT raise platform while machine is on a truck, fork lift or other device.
DO NOT use ladders, scaffolds, or other means to increase size or platform height.
DO NOT use with damaged tires or wheels.

ALARM MEANS TIPOVER DANGER! LOWER PLATFORM IMMEDIATELY

1. 2. 3.

TO AVOID TIPOVER HAZARDS USE ON FLAT LEVEL AND SOLID SURFACES ONLY

ELECTRICAL SHOCK CAN KILL YOU

This machine is not electrically insulated. Maintain 10 feet minimum clearance from electrical power lines and apparatus. This machine will not protect you from shock. Allow for platform sway, rock, or sag. If voltage is 300 V to 50 kV stay at least 10 feet (3.1m) away. If voltage is more than 65 kV talk with your supervisor or read the Operator's Manual on this machine for safe distances.

DO NOT use this machine without the ratings and the entry gate, chain or bar in place. You could fall out and hurt or kill yourself!
DO NOT use this machine if it is not working right, or if any part of it is damaged, worn, or missing. An accident could cause injury or death.

DO NOT let an untrained or unauthorized person use this machine. When you leave the machine unattended, remove the key, or turn off the battery switch on the base of the machine and lock the battery switch in the off position.
DO NOT replace components critical to machine stability, such as batteries and wheel equipment, with lighter weight or non-factory approved substitutes.

NOTE: STUDY THE OPERATORS MANUAL BEFORE OPERATING THIS MACHINE.

0372000

▲ DANGER

DO NOT ALTER OR DISABLE LIMIT SWITCHES, SAFETY SWITCHES, OR INTERLOCKS.

451986

▲ DANGER

Using incorrect parts can cause cylinder failure. Death or serious injury can result.

Use only:

APPROVED PARTS

Snorkel

0074311

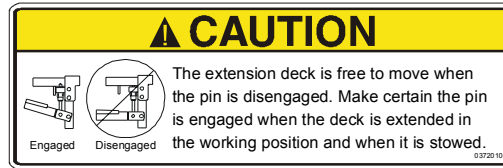

0372010

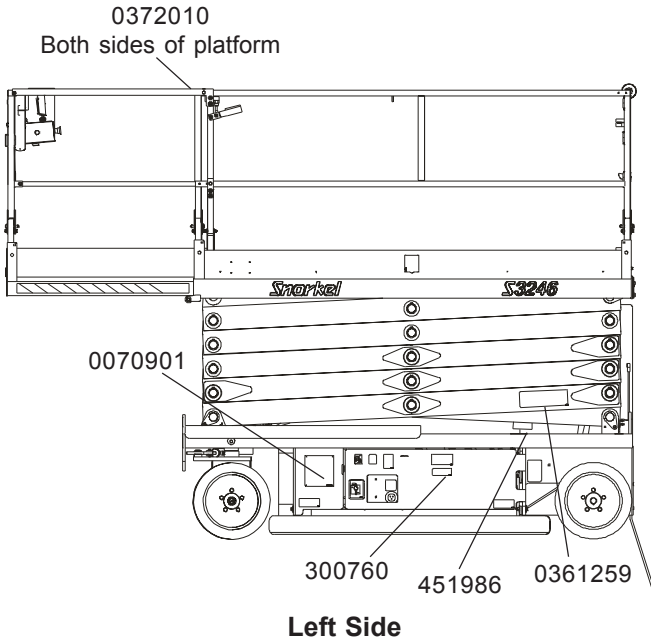

Left Side

Snorkel		SERIAL NUMBER	
MODEL NUMBER		SLOPE SENSOR ALARM SETTING	deg
MONTH/YEAR OF MANUFACTURE		MAXIMUM WHEEL LOAD	lbs kg
MAXIMUM MACHINE WEIGHT	lbs kg	BATTERY POWERED MODELS ONLY	DRIVE MOTORS V BATTERIES V Ah
ENGINE POWERED MODELS	hp kw	MAXIMUM ALLOWABLE WIND SPEED	mi/h m/s
MAXIMUM ALLOWABLE MANUAL FORCE (SIDE PULL)	lbs N	MAXIMUM PLATFORM REACH	ft m
PLATFORM SIZE	ft cm	MAXIMUM DRIVE HEIGHT	ft m
RATED NUMBER OF OCCUPANTS		UNRESTRICTED PLATFORM CAPACITY	lbs kg
CAUTION			
Do not remove any weight from this machine. Any weight added must be distributed equally on each side. Proper stability and side weights of this machine are based on the platform size shown above.			
Axle weights with machine in the stowed - travel position.			
STEER AXLE	lbs kg	DRIVE AXLE	lbs kg

0070901



300760



451986

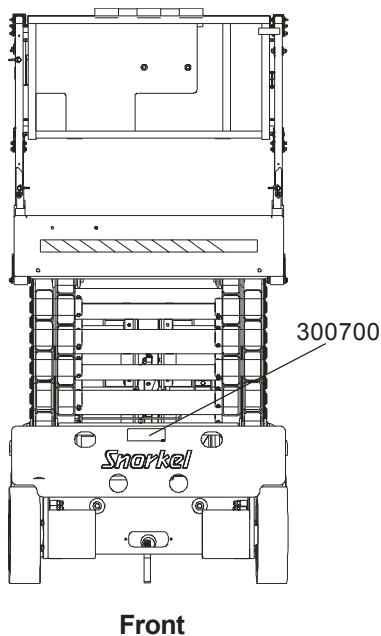

Front

⚠ DANGER

Proper position for safety prop use

Death or serious injury might result if safety prop is not used and/or properly positioned. Use safety prop at all times when servicing machine with platform raised.

PROPER USE OF SAFETY PROP

1. Remove all material from platform.
2. Raise platform until the open height is wide enough to position the safety prop.
3. Place safety prop in the proper position.
4. Remove hands and arms from scissors area.
5. Lower platform until scissors are supported by safety prop.

TO STORE SAFETY PROP

1. Raise platform until the open height is wide enough to position the safety prop.
2. Place the safety prop in the storage position.

0361259



300700

Prestart Inspection Checklist

Item	Inspect For	Ok
Operator's Manual	In manual holder	
Electrical System		
Battery fluid level	Proper level	
Battery terminals	Clean, connectors tight	
Battery charger	Proper operation	
Cables and wiring harness	No wear or physical damage	
Hydraulic System		
Fluid level	Between full and add marks with platform stowed	
Hoses, tubes, and fittings	No leaks	
Free-wheeling valve	Fully closed	
Tires and Wheels	Good condition	
Ground Strap	In place and securely fastened	
Lower Control Station		
Operating controls	Proper operation	
Emergency stop	Shuts off lower controls	
Lowering alarm and interrupt	Sounds when platform lowers	
Pothole Protector Interlock	Proper operation	
Emergency Lowering	Proper operation	
Safety Prop	No damage or deformation	
Flashing Light	Proper operation	
Structures		
Weldments	Welds intact, no damage or deformation	
Slide pads	In place, no damage or deformation	
Fasteners	In place and tight	
Upper Control Station		
Guardrail system	Welds intact, no damage or deformation	
Platform extension	Proper operation	
Swing-down rails	Fasteners in place, proper operation	
Brakes	Proper operation	
Operating controls	Proper operation	
Emergency stop	Shuts off upper controls	
Lowering alarm and interrupt	Sounds when platform lowers	
Drive motion alarm	Sounds when aerial platform moves	
Electrical power outlet	Proper operation	
Battery condition indicator	Proper operation	
Horn	Sounds when activated	
Placards and Decals	In place and readable	

Chapter 9 – Operation

The aerial platform may be operated from either the lower or upper controls.

⚠ Danger

The aerial platform is not electrically insulated. Death or serious injury will result from contact with, or inadequate clearance from, an energized conductor. Do not go closer than the minimum safe approach distance as defined by ANSI or national safety regulations.

Pinch points may exist between moving components. Death or serious injury will result from becoming trapped between components, buildings, structures, or other obstacles. Make sure there is sufficient clearance around the machine before moving the chassis or platform. Allow sufficient room and time to stop movement to avoid contact with structures or other hazards.

The aerial platform can tip over if it becomes unstable. Death or serious injury will result from a tip-over accident. Operate the aerial platform on a firm, flat, level surface. Avoid travel speeds and/or rough terrain that could cause sudden changes in platform position. Do not drive or position the aerial platform for elevated use near any drop-off, hole, slope, soft or uneven ground, or other tip-over hazard. Do not raise the platform in wind speeds above 12.5 m/s (28 mph).

The platform rated work load is the total weight of the personnel and equipment that may be lifted in the platform. The work loads are stated on the platform rating placard mounted at the rear of the platform.

⚠ Danger

The aerial platform can tip over if it becomes unstable. Death or serious injury will result from a tip-over accident. Do not exceed the capacity values indicated on the platform rating placard.

Capacity values indicate the rated lifting capacity and do not indicate aerial platform stability.

The operator bears ultimate responsibility for ensuring that the aerial platform is properly set up for the particular conditions encountered.

Preparing for Operation

Make certain the batteries are charged and the charger is unplugged before operating the aerial platform. Use the following procedure to prepare the aerial platform for operation.

1. Perform a prestart inspection (refer to as Chapter 8).
2. Close and latch the battery and hydraulic trays.

3. Place the battery disconnect switch in the on position.

Lower Controls

The lower controls override the upper controls. This means that the lower controls may be used to operate the platform regardless of the position of the upper controls emergency stop button.

Only the platform raise and lower functions may be operated from the lower controls. The lower controls may be used for initial set up of the aerial platform and for positioning the platform while testing or during inspection.

Use the following procedure to raise or lower the platform using the lower controls.

1. Pull the emergency stop button outward (refer to Figure 9.1).

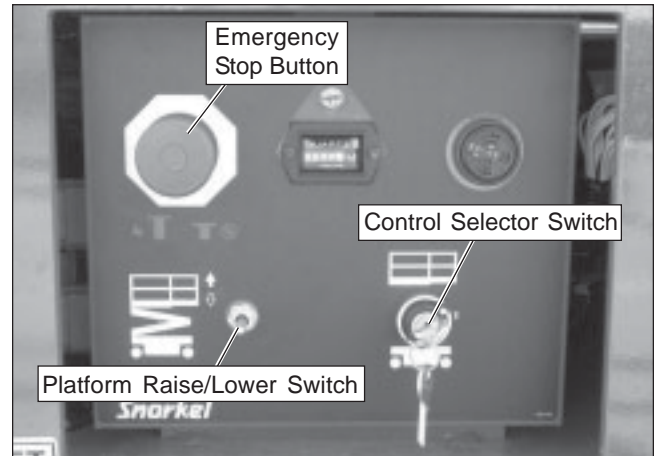

Figure 9.1 – Lower Controls

2. Insert the key into the control selector switch and turn the switch to the lower controls position.
3. Hold the platform raise/lower toggle switch up to raise the platform and down to lower it.
4. Release the toggle switch to stop movement.

Upper Controls

The upper controls (refer to Figure 9.2) may be used for driving the aerial platform and positioning the platform while on the job.

Before operating from the upper controls, properly set up the aerial platform as described under Preparing for Operation. Use the following procedure to operate the aerial platform from the upper controls.

1. From the lower controls, insert the key into the control selector switch and turn the switch to the lower controls position.

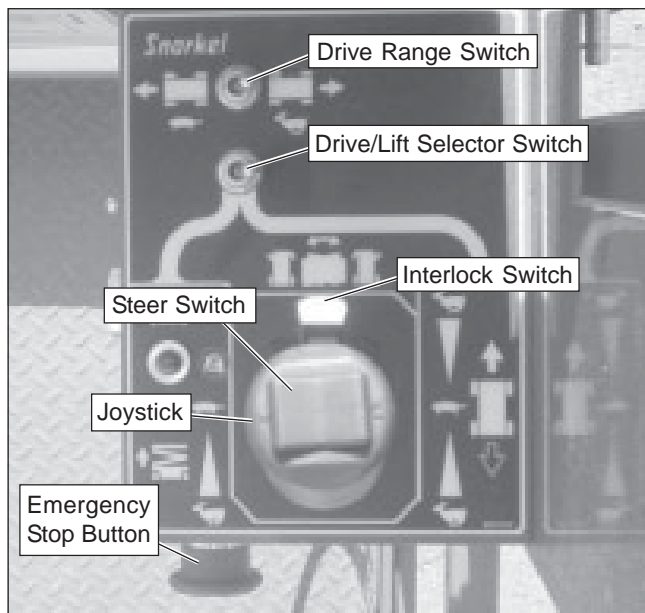

Figure 9.2 – Upper Controls

Note

The upper controls will not operate while the control selector is in the lower position.

2. Enter the platform and lower the gravity gate. Make certain the entry gate is securely pinned in place.
3. Pull the emergency stop button out.
4. The aerial platform may be driven and the platform may be raised and lowered from the upper controls.

Driving

⚠ Danger

The aerial platform can tip over if it becomes unstable. Death or serious injury will result from a tip-over accident. Do not drive an elevated aerial platform on soft, uneven, or sloping surfaces. Do not drive a fully stowed machine on grades that exceed 25 percent.

A fully stowed machine may be operated on grades up to 25 percent. A grade of 25 percent is a 0.76 m (30") vertical rise in 3.05 m (10') horizontal length.

⚠ Warning

Death or serious injury can result from improperly driving or steering the aerial platform. Read and understand the information in this manual and on the placards and decals on the machine before operating the aerial platform on the job.

Use the following procedure to operate the drive functions.

1. Place the drive/lift selector switch (refer to Figure 9.2) in the drive position.
2. Squeeze and hold the interlock switch against the joystick.
 - To move forward, slowly push the joystick forward.
 - To move backward, slowly pull the joystick backward.

Drive Range Switch

The drive range switch has two positions to select drive wheel operation:

- High (Rabbit) – for normal driving conditions.
- Low (Turtle) – for driving on grades up to 25 percent that require low speed and high torque operation, where high range is not sufficient to climb the grade.

In high the machine will travel up to 3.2 km/h (2 mph) when the platform is raised less than 2.4 m (8') and up to 0.8 km/h (0.5 mph) when the platform is raised above 2.4 m (8'). Place the drive range switch in high for normal machine operation.

Place the drive range switch in low, with the platform fully lowered and the extension deck securely pinned, before driving up a ramp to load the machine for transport.

⚠ Caution

The extension deck is free to move when the pins are disengaged. Make certain the pin is engaged when the deck is extended in the working position and when it is stowed.

Drive Speeds

The drive speed is proportional to the joystick position. The farther the joystick is moved, the faster the travel speed.

Drive speed ranges are interlocked through a limit switch that senses scissors arm position. When the platform is elevated below approximately 2.1 to 2.4 m (7 to 8 feet), the aerial platform may be driven within the full range of drive speeds. Above 2.1 to 2.4 m (7 to 8 feet) of elevation, drive speed is limited to 0.8 km/h (0.5 mph).

⚠ Warning

The potential for an accident increases when safety devices do not function properly. Death or serious injury can result from such accidents. Do not alter, disable, or override any safety device.

Do not use the aerial platform if it drives faster than 0.8 km/h (0.5 mph), which is 6.7 m (22') in 30 seconds, when elevated above 2.4 m (8').

Drive/Lift Level Sensor Interlock

When the platform is elevated above 2.1 to 2.4 m (7 to 8 feet), lift and drive functions are interlocked through a level sensor system. If the chassis is tilted more than two degrees side-to-side or four degrees front-to-rear, platform raise and drive functions are disabled and an alarm sounds when those controls are activated.

If the drive/lift level sensor interlock shuts off the platform raise and drive functions, lower the platform and drive to a level surface.

Platform raise and drive functions may also be disabled by the pothole protection interlock.

Steering

The steer control switch is located on the joystick (refer to Figure 9.2). Use the following procedure to steer the aerial platform using the upper controls.

1. Squeeze and hold the interlock switch against the joystick.
 - To turn to the left, tap lightly on the left side of the steer switch.
 - To turn to the right, tap lightly on the right side of the steer switch.

Note

Holding the steer switch down too long may result in a sharp turn. This is especially true when driving and steering at the same time. It may be easier to turn the wheels in small increments using a series of quick taps on the steer switch.

2. Set the steer wheels straight ahead after completing a turn. The steering wheels are not self-centering.

Platform

Use care when entering and exiting the platform to avoid slipping and/or falling. Make certain the entry gate is properly pinned in position. Fully lower the gravity gate when the platform is occupied.

▲ Danger

The potential for an accident increases when the swing-down rails are lowered. Death or serious injury can result from such accidents. Do not elevate the platform with the swing-down rails lowered.

Be sure the swing-down rails are up and the pins are all installed, anytime the machine is not being transported.

Raising and Lowering

The raise speed is proportional to the joystick position. The farther the joystick is moved, the faster the platform raises. There is only one lowering speed.

1. Place the drive/lift selector switch (refer to Figure 9.2) in the lift position.
2. Squeeze and hold the interlock switch against the joystick.
 - To raise the platform, slowly pull the joystick back until the desired speed is reached.
 - To lower the platform, slowly push the joystick forward.

Lowering Interrupt

When the platform is lowered to about 1.5 m (5') lowering stops. The platform will not lower for five seconds regardless of the joystick position.

Center the joystick in neutral to reset the lowering function, then continue to lower the platform.

Overload Protection

When the load in the platform is near or at rated capacity, an alarm will sound and the red light on the upper controls (refer to Figure 9.3) will flash.

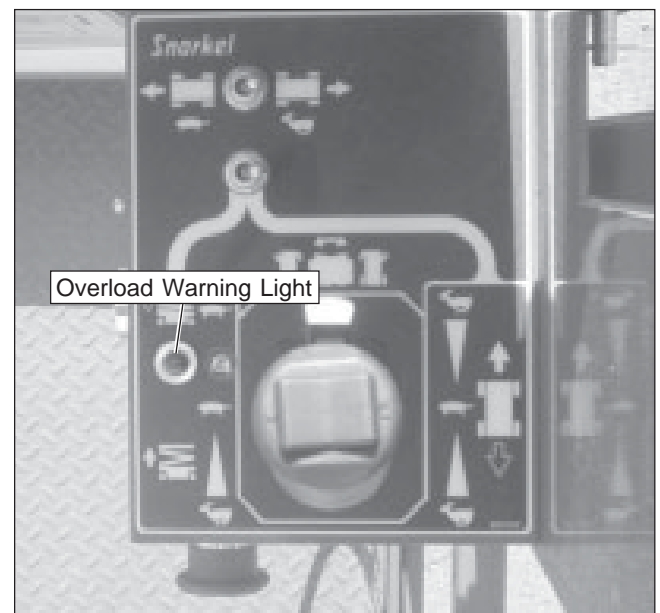

Figure 9.3 – Upper Controls

The alarm and light warn the operator that the platform is close to becoming overloaded. All functions remain fully operational.

▲ Danger

The aerial platform can tip over if it becomes unstable. Death or serious injury will result from a tip-over accident. Do not exceed the capacity values indicated on the platform rating placard.

If the platform is fully lowered and is overloaded, when it is elevated just past 1.8 m (6'), a control module will stop the lift and drive functions and the alarm will sound and the warning light will flash. The platform can still be lowered to remove the excess load.

If the platform is elevated just past 1.8 m (6') and material is added to the platform overloading it, a control module will stop the lift, drive and lower functions and the alarm will sound and the warning light will flash. In this case, remove the load in excess of rated capacity and cycle the emergency stop button at the upper controls to return to normal operation.

Extending

The platform can be extended and securely locked into position. Use the following procedure to extend or retract the platform to full or half extension.

⚠ Caution

The extension deck is free to move when the pins are disengaged. Personal injury may result from extending the platform deck while the aerial platform is on a slope. Do not attempt to extend or retract the platform unless the aerial platform is on a level surface.

1. Push down on the handle on each side of the front of the platform (refer to Figure 9.4).

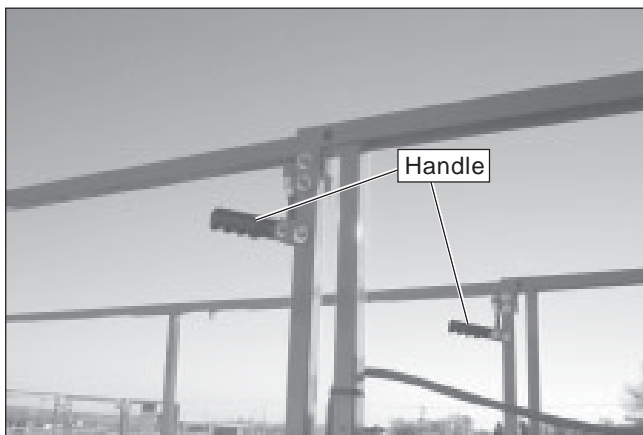

Figure 9.4 – Platform

2. Stand on the main deck of the platform, facing the front of the platform, and push forward while holding the handles down to extend the deck.
3. Release the handles and make sure the pins are engaged in the holes when the platform is extended to lock it in place.

⚠ Caution

The extension deck is free to move when the pins are disengaged. Make certain the pin is engaged when the deck is extended in the working position and when it is stowed.

4. Try to move the rails back and forth to make sure the platform extension deck is locked in position. The handle should angle upward when the extension deck is locked in position.

Swing-Down Rails

The platform rails may be lowered approximately 63.5 cm (25") to fit the machine under low height obstructions or for transporting.

⚠ Warning

The potential for an accident increases when the swing-down rails are lowered. Death or serious injury can result from such accidents. Do not elevate the platform with the swing-down rails lowered. Use extreme care when moving the aerial platform while the swing-down rails are lowered.

Use the following procedure to lower the platform guardrails.

1. Remove the pin from the platform gate. Fasten the gate to the mid rail on the right side of the platform (refer to Figure 9.5).



Figure 9.5 – Platform Gate

2. Remove the pin that connects the upper controls to the guardrails (refer to Figure 9.6). Lay the upper controls on the floor of the platform.

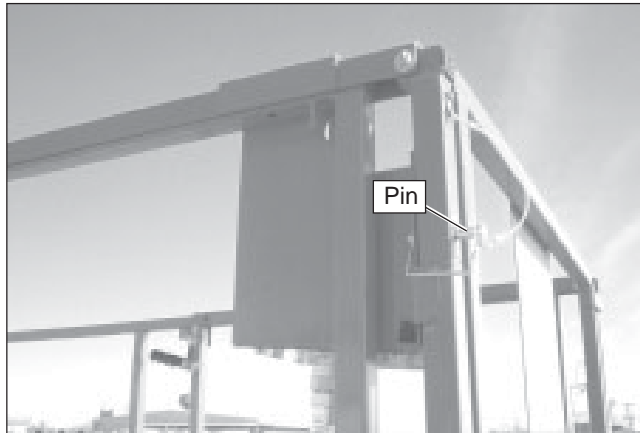

Figure 9.6 – Upper Controls

- Remove the pin that connects the front panel to the guardrails on the left side of the platform (refer to Figure 9.7). Fasten the front panel to the mid rail on the right side of the platform.

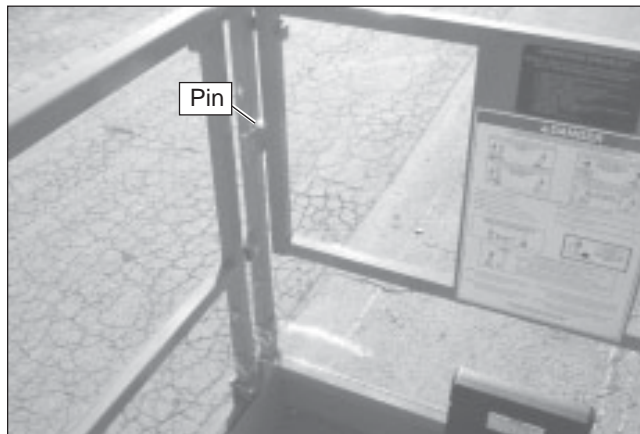

Figure 9.7 – Platform Front Panel

- Remove the three pins on the right side of the platform and fold the guardrails down to rest on the floor of the platform.

Note

It may be necessary to extend the platform approximately 15 cm (6") to remove the pins at the front of the platform. If so, make certain to relock the extension deck in the stowed position with the handles angled upward.

- Remove the three pins on the left side of the platform and fold the guardrails down to rest on the right side guardrails.
- Reverse this procedure to reposition the rails.

Swing-Out Trays

Batteries and hydraulic components are enclosed in swing-out trays (refer to Figure 9.8) on each side of the chassis.

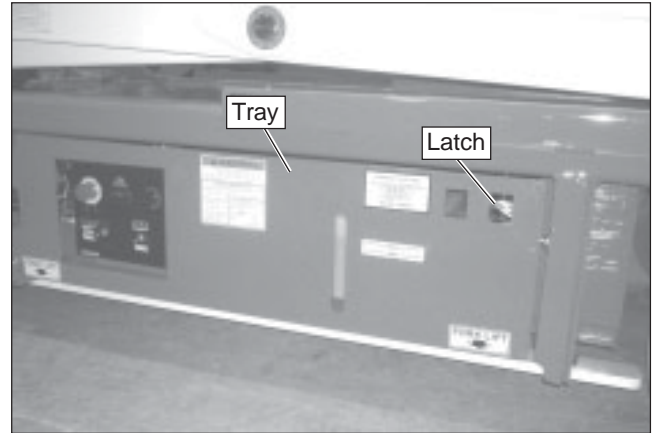

Figure 9.8 – Swing-Out Tray

The tray on the right side of the chassis contains the lower controls, brake release hand pump, hydraulic directional control valve, hydraulic pump, reservoir, and the hydraulic fluid filter. The tray on the left side contains the four batteries and the battery charger.

⚠ Danger

The aerial platform can tip over if it becomes unstable. Death or serious injury will result from a tip-over accident. Do not open the trays when the platform is raised more than eight feet.

To open a tray, raise up on the latch and swing the tray open.

Wallboard Loading

The platform gate (refer to Figure 9.9) may be used for loading wallboard or other material. It is hinged on the left side of the platform and is pinned on the right.



Figure 9.9 – Platform Gate

For easy loading of work materials in the platform, remove the pin and swing the gate open. Close the gate and replace the pin after loading the platform.

Chapter 10 – Stowing and Transporting

To prevent unauthorized use and damage, properly stow the aerial platform at the end of each work day. It must also be properly stowed while transporting.

Stowing

Use the following procedure to properly stow the aerial platform.

1. Retract the platform extension deck and ensure both lock pins are engaged in the holes with the handles angled upward.

⚠ Caution

The extension deck is free to move when the pins are disengaged. Make certain the pin is engaged when the deck is extended in the working position and when it is stowed.

2. Fully lower the platform.
3. Push the emergency stop button in on the lower control panel.
4. Remove the key from the control selector switch.
5. Turn the battery disconnect switch off and lock it.
6. Securely close the swing-out trays.

Transporting

The aerial platform may be moved on a transport vehicle. Depending on the particular situation, the aerial platform may be lifted with a forklift, winched, driven, or hoisted onto a vehicle such as a truck or trailer. Lifting with a forklift is the preferred method.

The equipment used to load, unload, and transport the aerial platform must have adequate capacity. The gross vehicle weight is listed in Chapter 2 and is stamped on the serial number placard.

The user assumes all responsibility for choosing the proper method of transportation, and the proper selection and use of transportation and tie-down devices, making sure the equipment used is capable of supporting the weight of the aerial platform and that all manufacturer's instructions and warnings, regulations and safety rules of their employer, the DOT and/or any other state or federal law are followed.

Lifting With a Forklift

Use the following procedure to lift the aerial platform with a forklift.

1. Properly stow the aerial platform.
2. Remove all personnel, tools, materials, or other loose objects from the platform.

3. If lifting from the rear of the machine, insert the forklift forks into the pockets (refer to Figure 10.1).

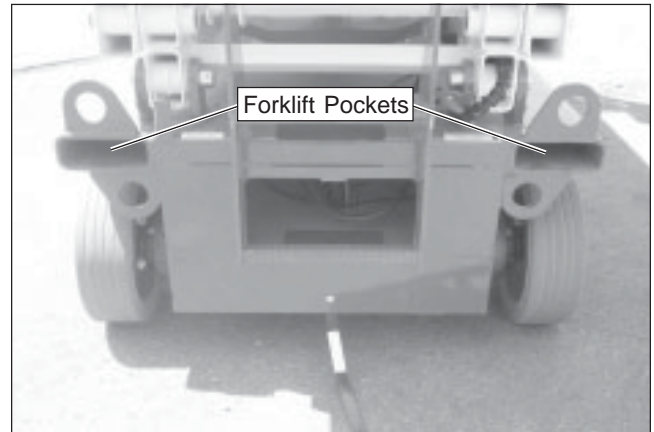

Figure 10.1 – Rear of Chassis

⚠ Caution

Lifting the aerial platform with the forklift forks positioned improperly can produce enough force to damage machine components. When lifting the machine from the side, place the forklift forks directly under the designated lift points.

4. If lifting from either side of the machine, place the forklift forks directly under the designated points under the pothole protector skid (refer to Figure 10.2).

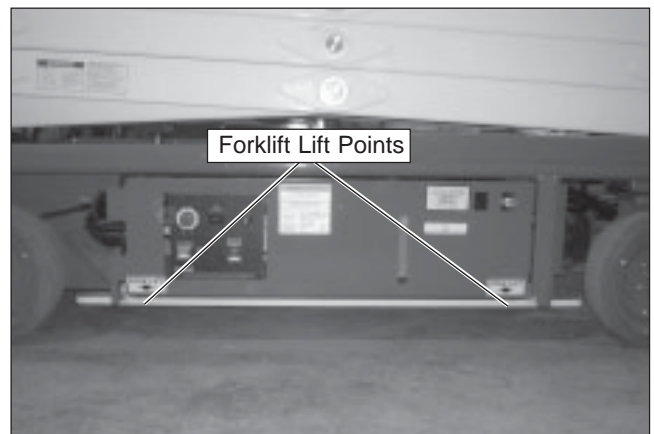

Figure 10.2 – Side of Chassis

5. Do not raise the aerial platform higher than necessary to transport it. Drive the forklift slowly and carefully when transporting the aerial platform.

Winching

Use a winch to load and unload the aerial platform on ramps that exceed 25 percent grade. A 25 percent grade is a 0.76 m (30") vertical rise in 3.05 m (10') horizontal length. A winch may also be used when poor traction, uneven surfaces, or stepped ramp transitions make driving hazardous.

Use the following procedure to winch the aerial platform onto the transport vehicle.

1. Position the transport vehicle so the aerial platform will not roll forward after it is loaded.
2. Remove any unnecessary tools, materials, or other loose objects from the platform.
3. Drive the machine to the foot of the loading ramp with the front wheels nearest the ramp. Make sure the machine is centered with the ramps and that the steering wheels are straight.
4. Properly stow the aerial platform.

⚠ Warning

The aerial platform is free to move when the brakes are released. Death or serious injury could result. Re-enable the brakes before operating the aerial platform.

5. Chock the wheels to prevent uncontrolled motion of the aerial platform.
6. Unlatch and swing out the hydraulic tray on the right side of the chassis. Push and release the brake release hand pump several times to release the brakes. The hand pump is located on the main control valve (refer to Figure 10.3).

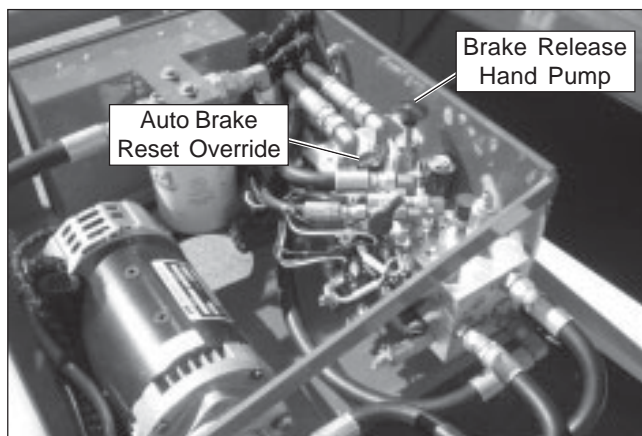

Figure 10.3 – Hydraulic Tray

7. Turn the free-wheeling valve counterclockwise to the fully open position. The free-wheeling valve is located on the drive valve at the rear of the chassis (refer to Figure 10.4).

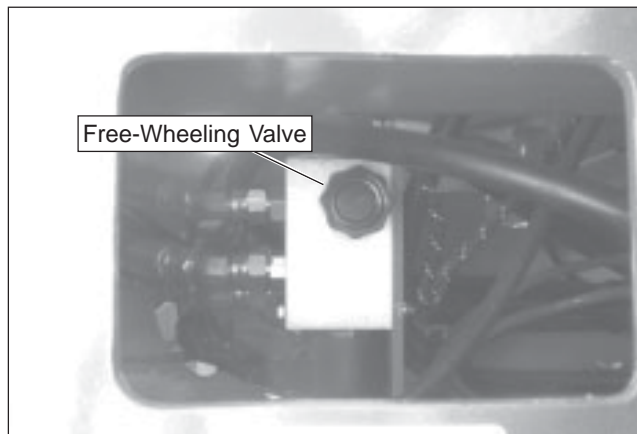

Figure 10.4 – Rear of Chassis

8. Attach the winch line to the tie-down lugs (refer to Figure 10.5) on the front of the chassis.

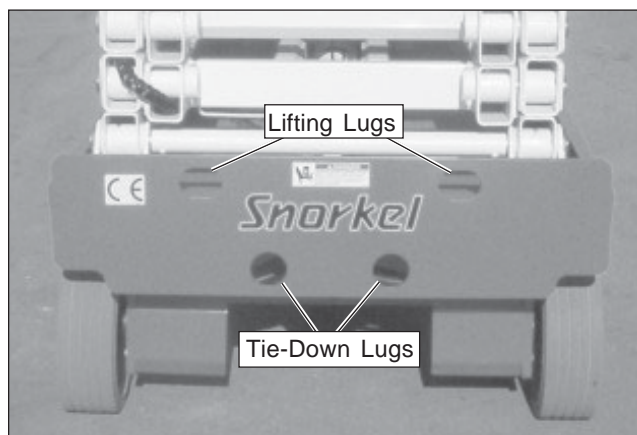

Figure 10.5 – Front of Chassis

9. Remove the wheel chocks and use the winch to position the aerial platform on the transport vehicle.
10. Close the free-wheeling valve.
11. Drive the aerial platform forward or backward and then stop, to reset the parking brakes.
12. Verify that the drive system and brakes operate properly before operating the aerial platform.
13. If the brakes do not reset, do not operate the aerial platform. Refer to Chapter 12 – Troubleshooting.

Driving

⚠ Danger

The aerial platform can tip over if it becomes unstable. Death or serious injury will result from a tip-over accident. Do not drive on ramps that exceed 25 percent grade, or where conditions of the ramp could cause driving to be hazardous.

Use a winch to load and unload the aerial platform on ramps that exceed a 25 percent grade. A 25 percent grade is a 0.76 m (30") vertical rise in 3.05 m (10') horizontal length. A winch may also be used when poor traction, uneven surfaces, or stepped ramp transitions make driving hazardous.

Drive the aerial platform onto the transport vehicle if a winch is not available and the ramp incline is within the 25 percent grade capability of the aerial platform.

Use the following procedure to drive the aerial platform onto the transport vehicle.

1. Position the transport vehicle so the aerial platform will not roll forward after it is loaded.
2. Chock the vehicle wheels so it cannot roll away from the ramp while the aerial platform is loaded.
3. Remove any unnecessary tools, materials, or other loose objects from the platform.
4. Retract the platform extension deck and ensure both lock pins are engaged in the holes with the handles angled upward. Fully lower the platform.

⚠ Caution

The extension deck is free to move when the pins are disengaged. Make certain the pin is engaged when the deck is extended in the working position and when it is stowed.

5. Drive the aerial platform to the foot of the loading ramp with the front wheels nearest the ramp. Make sure the aerial platform is centered with the ramps and that the steering wheels are straight.
6. Place the drive range switch in low (turtle) for climbing or descending a ramp.
7. Drive the aerial platform on or off the transport vehicle in a straight line through the grade transitions with minimal turning.

Hoisting

Use a four point sling arrangement attached to the lifting lugs when hoisting the aerial platform. Machine damage can occur if the sling is attached to the chassis, scissors structure, or platform.

⚠ Warning

The potential for an accident increases when the aerial platform is lifted using improper equipment and/or lifting techniques. Death or serious injury can result from such accidents. Use proper equipment and lifting techniques when lifting the aerial platform.

Know the weight of the aerial platform and the capacity of the lifting devices before hoisting. Lifting devices include the hoist or crane, chains, straps, cables, hooks, sheaves, shackles, slings, and other hardware used to support the machine. The gross vehicle weight is stamped on the serial number placard and is listed in Chapter 2.

The user assumes all responsibility for making sure the equipment used is capable of supporting the weight of the aerial platform and that all manufacturer's instructions and warnings, regulations and safety rules of their employer and/or any state or federal law are followed.

Use the following procedure to hoist the aerial platform onto the transport vehicle.

1. Properly stow the aerial platform.
2. Inspect the front lifting lugs (refer to Figure 10.5) and the rear lifting lugs (refer to Figure 10.6) to make sure they are free of cracks and are in good condition. There are two lugs on the rear of the chassis and two on the front. Have any damage repaired by a qualified service technician before attempting to hoist the machine.

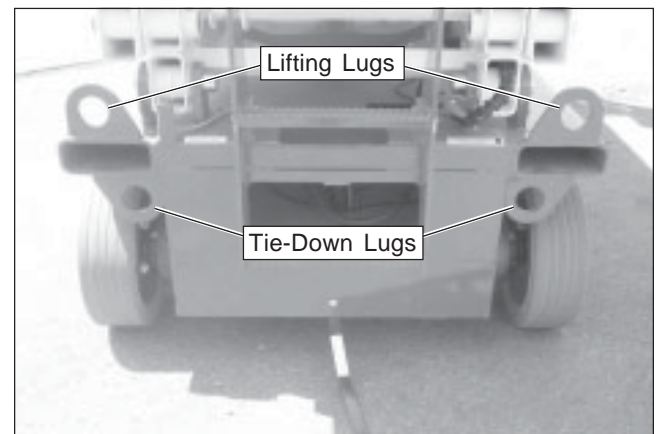

Figure 10.6 – Rear of Chassis

3. Remove all personnel, tools, materials, or other loose objects from the platform.
4. Connect the chains or straps to the lifting lugs using bolted shackles. Hooks that fit properly in the lugs and that have latching mechanisms to prevent them from falling out under a slack line condition may also be used.

Do not run the sling cable through the lifting lugs. Cable damage and/or failure can result from the cable contacting the sharp corners of the lift lug. There is no effective way of putting a corner protector in the hole of the lug.

5. Use spreader bars of sufficient length to keep the chains, straps, or cables from contacting the scissors structure or platform. When using cables, use rigid corner protectors at any point where the cable contacts on sharp corners to prevent damaging the cable. Careful rigging of the spreaders is required to prevent machine damage.
6. Use the hoist or crane to carefully raise and position the aerial platform onto the transport vehicle.

Securing for Transport

Use the following procedure to secure the aerial platform on the transport vehicle.

1. Chock the wheels.
2. Remove all personnel, tools, materials, or other loose objects from the platform.
3. Properly stow the aerial platform.

4. Place wood blocks under the front ends of the pot-hole protection skids to limit excessive loading on the front drive wheel bearings.
5. Place the lower controls emergency stop switch in the off position.
6. Turn the battery disconnect switch off.

Caution

Ratchets, winches, and come-alongs can produce enough force to damage machine components. Do not over tighten the straps or chains when securing the aerial platform to the transport vehicle.

7. Use chains or straps to securely fasten the aerial platform to the transport vehicle using the front and rear tie-down lugs as attachment points. Proper tie-down and hauling is the responsibility of the carrier.

Chapter 11 – Emergency Operation

If the aerial platform cannot be operated due to a loss of hydraulic power, such as motor or pump failure, the platform lift cylinder(s) and drive wheels may be operated manually. Refer to the Emergency Lowering or Towing section for the appropriate procedure.

Emergency Lowering

Use the following procedure to lower the platform.

1. Retract the platform extension, if possible.
2. Locate the emergency lowering handle at the rear of the aerial platform (refer to Figure 11.1).

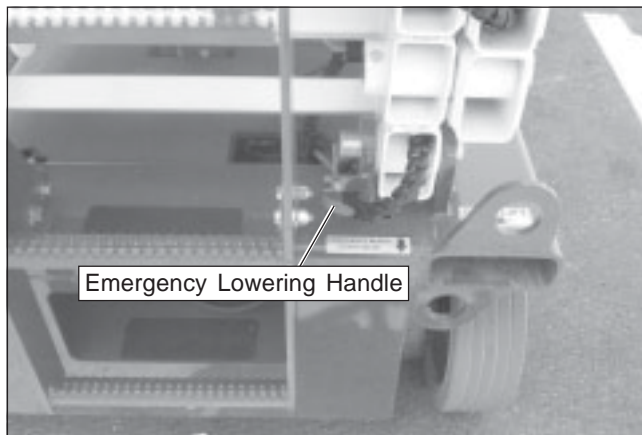

Figure 11.1 – Rear of Chassis

3. Make sure there is nothing in the way to obstruct the platform when it lowers.

⚠ Danger

Pinch points exist on the scissors structure. Death or serious injury will result from becoming trapped within the scissors structure. Make sure all personnel stand clear while lowering the platform with the emergency lowering handle.

4. Pull the handle outward to lower the platform. Push the handle all the way back in after lowering the platform.

Towing

The aerial platform may be pushed or pulled after disengaging the brakes. Use the following procedure to manually disengage the brakes.

⚠ Warning

The aerial platform is free to move when the brakes are released. Death or serious injury could result. Re-enable the brakes before operating the aerial platform.

1. Chock the wheels to prevent uncontrolled motion of the aerial platform.

2. Turn the battery disconnect switch off.
3. Unlatch and swing out the hydraulic tray on the right side of the chassis. Push and release the brake release hand pump several times to release the brakes. The hand pump is located on the main control valve (refer to Figure 11.2).

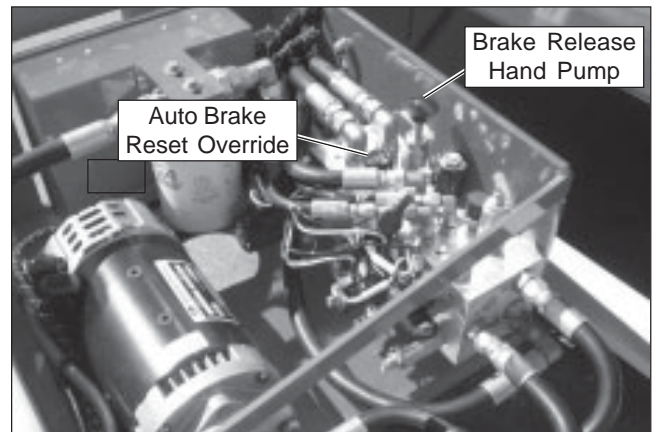

Figure 11.2 – Hydraulic Tray

4. Turn the free-wheeling valve counterclockwise to the fully open position. The free-wheeling valve is located on the drive valve at the rear of the chassis (refer to Figure 11.3).

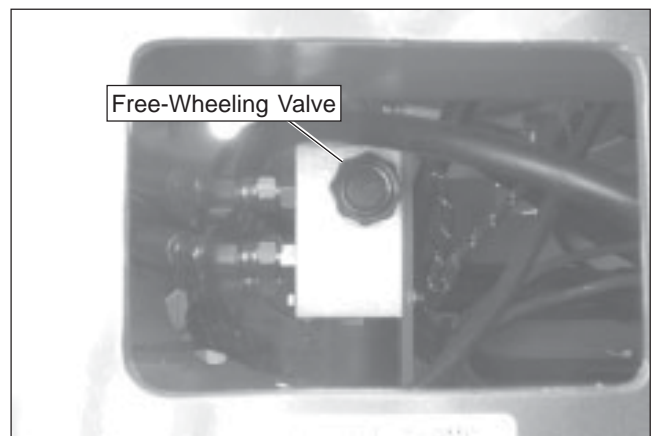

Figure 11.3 – Rear of Chassis

5. Do not exceed 3.2 km/h (2 mph) when towing.

⚠ Warning

The aerial platform is free to move when the brakes and free-wheeling valve are disabled. Death or serious injury could result. Close the free-wheeling valve and reset the brakes before operating the aerial platform.

6. Close the free-wheeling valve after moving the aerial platform.

7. Drive the aerial platform forward or backward and then stop, to reset the parking brakes.
8. Verify that the drive system and brakes operate properly before operating the aerial platform.
9. If the brakes do not reset, do not operate the aerial platform. Refer to Chapter 12 – Troubleshooting.

Chapter 12 – Troubleshooting

The troubleshooting chart may be used to locate and eliminate situations where machine operation may be interrupted. If the problem cannot be corrected with the

action listed, stow the machine and remove it from service. Repairs must be made by qualified maintenance personnel.

Troubleshooting Chart

Symptom	Possible Cause	Corrective Action
All functions stop working.	Motor or pump failure.	Manually stow the machine.
	Low fluid level in reservoir.	Check fluid level. Add correct type of fluid if necessary.
	Electrical system malfunction.	Stow the machine and do not operate until repairs are made.
Platform will not raise or lower from lower controls.	Control selector switch in the upper control position.	Place switch in the lower control position.
	Battery disconnect switch is turned off.	Place switch in the on position.
	Emergency stop button is pushed inward to the off position.	Pull the emergency stop button outward to the on position.
Upper controls will not work.	Control selector switch is in the lower control position.	Place switch in the upper control position.
	Battery disconnect switch is turned off.	Place switch in the on position.
	Emergency stop button is pushed inward to the off position.	Pull the emergency stop button outward to the on position.
Platform will not raise or lower from upper controls.	Drive/lift selector is in the drive position.	Place switch in the lift position.
Platform will not raise and alarm is sounding.	Machine is not on a level surface.	Lower the platform and drive to a level surface.
Platform drifts down.	Emergency lowering handle not properly disengaged.	Ensure handle returns to normal operating position.
	Hydraulic system malfunction.	Stow the machine and do not operate until repairs are made.
Platform will not lower.	Safety prop in place.	Stow the safety prop.
Drive functions don't work.	Drive/lift selector is in the lift position.	Place the switch in the drive position.
	Machine is not on a level surface or too steep a grade.	Lower the platform and drive to a level surface.
	Free-wheeling valve is open.	Fully close the free-wheeling valve.

Symptom	Possible Cause	Corrective Action
Drive functions don't work.	Load capacity exceeded.	Remove load from platform. Refer to platform capacity placard for maximum capacity.
	Low hydraulic system pressure.	Stow the machine and do not operate until repairs are made.
Machine will not climb a 25 percent grade.	Drive range selector not in low.	Place the switch in the low (turtle) position.
Only slow drive speed works.	Platform elevated above 2.1 to 2.4 m (7 to 8 feet).	Normal operation, lower platform to drive machine at faster speed.
	Drive range selector is in the low position.	Place the switch in the high (rabbit) position.
Machine will not steer.	Joystick interlock switch not engaged.	Engage the interlock switch before operating the steer switch.
Wheels won't turn when winching or pushing.	Brakes engaged.	Manually release the brakes using the brake release hand pump.
	Free-wheeling valve closed.	Fully open free-wheeling valve.
	A hydraulic function was operated after the brakes were disengaged, which reset the brakes.	Manually release the brakes using the brake release hand pump.
Brakes don't hold or won't reset after towing.	Brakes not fully engaged due to trapped hydraulic pressure in the brake release system.	Relieve the pressure with the auto brake reset override on the main control valve by turning the knob fully in (cw) and then fully out (ccw). Refer to Figure 10.3 or 11.2.
Tilt alarm does not work.	Platform is not raised more than 2.1 to 2.4 m (7 to 8 feet).	Normal operation. The tilt alarm is not active until the platform is raised more than 2.1 to 2.4 m (7 to 8 feet).
Electrical outlet does not work.	Power supply not plugged in.	Plug a source of power into the power-input connector at front of chassis.
	GFCI is tripped.	Push reset button on outlet.
Ammeter does not indicate a reading when charging the batteries.	No source of power.	Make sure power source is plugged in and turned on.
	Charger power fuse is blown.	Stow the machine and do not operate until repairs are made.

Symptom	Possible Cause	Corrective Action
Hydraulic fluid temperature of 71°C (160°F) or more.	Prolonged driving or platform operation.	Stop operation until fluid cools.
	High pressure fluid return to reservoir caused by kinked or twisted hose.	Remove the kink or twist from the hose. Let fluid cool before resuming operation.
	Hydraulic system component failure.	Stow the machine and do not operate until repairs are made.
Severe hydraulic leak.	Failure of hose, tube, fitting, seal, etc.	Stow the machine and do not operate until repairs are made.

Appendix A – Glossary

aerial platform – a mobile device that has an adjustable position platform, supported from ground level by a structure.

ambient temperature – the air temperature of the immediate environment.

ammeter – an instrument for measuring the strength of an electric current in amperes.

authorized personnel – personnel approved as assigned to perform specific duties at a specific location.

base – the relevant contact points of the aerial platform that form the stability support (e.g. wheels, casters, outriggers, stabilizers).

battery tray – a swing-out compartment that holds the batteries and the battery charger.

center of gravity – the point in the aerial platform around which its weight is evenly balanced.

chassis – the integral part of the aerial platform that provides mobility and support for the scissors structure.

fall restraint – a system that is used while working on a boom lift within the boundaries of platform guardrails to provide restraint from being projected upward from the platform. This system includes a harness or belt, lanyard, and a lanyard anchor. Although federal regulations, OSHA, ANSI, and Snorkel do not require the use of additional fall protection beyond the platform guardrails on scissor lift aerial platforms, local, state, or employer rules may require their use.

floor or ground pressure – the maximum pressure, expressed in pounds per square inch, a single wheel concentrates on the floor or ground.

free-wheeling valve – a needle valve that when adjusted open allows hydraulic fluid to flow through the wheel drive motors. This allows the aerial platform to be pushed or towed without damage to the drive motors.

gradeability – the maximum slope that the aerial platform is capable of travel.

guardrail system – a vertical barrier around the platform to prevent personnel from falling.

hazardous location – any location that contains, or has the potential to contain, an explosive or flammable atmosphere as defined by ANSI/NFPA 505.

hydraulic tray – a swing-out compartment that hold the electrical panel for the lower controls, the hydraulic directional control valve, the free-wheeling valve, the pump, and the hydraulic fluid filter.

level sensor – a device that detects a preset degree of variation from perfect level. The level sensor is used to prohibit certain aerial platform functions if operating on a slope greater than the preset value.

lower controls – the controls located at ground level for operating some or all of the functions of the aerial platform.

manufacturer – a person or entity who makes, builds, or produces an aerial platform.

maximum travel height – the maximum platform height or the most adverse configuration(s) with respect to stability in which travel is permitted by the manufacturer.

maximum wheel load – the load or weight that can be transmitted through a single wheel to the floor or ground.

Minimum Safe Approach Distance (M.S.A.D) – the minimum safe distance that electrical conductors may be approached when using the aerial platform. Also called M.S.A.D.

operation – the performance of any aerial platform functions within the scope of its specifications and in accordance with the manufacturer's instructions, the users work rules, and all applicable governmental regulations.

operator – a qualified person who controls the movement of an aerial platform.

personal fall arrest system – a fall protection system that is used while working on an unprotected edge (such as a roof top with no guardrail). This system includes a harness, lanyard or other connecting device, a fall arrestor, an energy absorber or decelerator, an anchorage connector, and a secure anchorage such as a building beam, girders or columns. An aerial platform is not a fall arrest anchorage.

platform – the portion of an aerial platform intended to be occupied by personnel with their tools and materials.

platform height – the vertical distance measured from the floor of the platform to the surface upon which the chassis is being supported.

pothole protection interlock – a safety feature that sounds and alarm and automatically stops the platform raise function if the pothole protection skids are prevented from lowering properly.

pothole protection system – a mechanical tip-over prevention system consisting of skids along the bottom of both sides of the chassis which lower as the platform is raised.

prestart inspection – a required safety inspection routine that is performed daily before operating the aerial platform.

qualified person – a person, who by reason of knowledge, experience, or training is familiar with the operation to be performed and the hazards involved.

rated work load – the designed carrying capacity of the aerial platform as specified by the manufacturer.

safety prop – a bar that when properly positioned mechanically prevents the platform from lowering.

stow – to place a component, such as the platform, in its rest position.

turning radius – the radius of the circle created by the wheel during a 360° turn with the steering wheels turned to maximum. Inside turning radius is the wheel closest to the center and outside turning radius is the wheel farthest from the center.

unrestricted rated work load – the maximum designed carrying capacity of the aerial platform allowed by the manufacturer in all operating configurations.

upper controls – the controls located on or beside the platform used for operating some or all of the functions of the aerial platform.

wheelbase – the distance from the center of the rear wheel to the center of the front wheel.

Appendix A – Glossary

working envelope – the area defined by the horizontal and vertical limits of boom travel that the platform may be positioned in.

working height – platform height plus six feet.



Product Warranty

1. Snorkel warrants each new machine manufactured and sold by it to be free from defects in material and workmanship for a period of one (1) year from date of delivery to a Customer. The warranty will apply subject to the machine being operated in accordance with the rules, precautions, instructions and maintenance requirements outlined in the Snorkel Operator's and Repair Parts Manuals.
2. Snorkel further warrants the structural components, specifically the mainframe chassis, turntable, booms and/or scissor arms of each new machine manufactured by it to be free from defects in material and workmanship for an additional period of four (4) years. Any such part or parts which, upon examination by the Snorkel Warranty Department, are found to be defective will be replaced or repaired by Snorkel through its local Authorised Dealer. The structural warranty specifically excludes adverse affects on the machine structure arising from damage, abuse or misuse of the equipment.
3. Machines may be held in an authorised Distributor stock for a maximum of six (6) months from the date of shipment from Snorkel, before the warranty period is automatically initiated.
4. It is the responsibility of the Distributor to complete and return a Predelivery/Warranty registration, before the act of rental/loan/demonstration of the machine or delivery to an end user.
5. The Customer and Dealer shall not be entitled to the benefits of this warranty and Snorkel shall have no obligations here under unless the "Predelivery and Inspection Record" has been properly completed and returned to the Snorkel Warranty department within fifteen (15) days after delivery of the Snorkel product to the Customer or Dealer's demonstration/rental fleet. Snorkel must be notified, in writing, within ten (10) days, of any machine sold to a Customer from a Dealer's rental fleet during the warranty period.
6. Any part or parts which upon examination by the Snorkel Product Support Department are found to be defective within the specified warranty period, will be replaced or repaired at the sole discretion of Snorkel, through Snorkel directly or an authorised Distributor, at no charge. Any parts replaced under warranty must be original Snorkel parts obtained through Snorkel directly or an authorised Distributor, unless expressly agreed otherwise in writing and in advance by Snorkel's Warranty Department.
7. All parts being claimed under warranty must be held available for return and inspection upon request for a period of 90 days from date of claim submission, it is necessary that all parts are individually tagged or marked with their part number and the warranty claim number. After 90 days all parts replaced under warranty which have not been returned to Snorkel should be destroyed. Failure to produce parts requested by the Warranty Administrator for inspection within a period of 14 days will result in the claim being automatically rejected in full. Materials returned for warranty inspection must have the following procedure:
 - Carefully packaged to prevent additional damage during shipping
 - Drained of all contents and all open ports capped or plugged
 - Shipped in a container tagged or marked with the RMA number
 - Shipped PREPAID. Any item(s) returned for warranty by any other means maybe refused and returned, unless prior approval is agreed with Snorkel.



Product Warranty

8. At the direction of the Snorkel Warranty Department, any component part(s) of Snorkel products to be replaced or repaired under this warranty program must be returned freight prepaid for inspection. An RMA (Returns Material Authorisation) must be requested from Snorkel Warranty Department, a copy to be placed with the returning component part(s).
9. All warranty replacement parts will be shipped freight prepaid (standard charge) from the Snorkel Parts/Service Department or from the Vendor to Dealer or Customer.
10. All warranty claims are subject to approval by Snorkel Service Department. Snorkel reserves the right to limit or adjust claims with regard to defective parts, labor or travel time based on usual and customary guidelines.

REPLACEMENT PARTS WARRANTY

- Any part replaced under this limited warranty is not subject to further warranty cover beyond the normal warranty period of the machine upon which the part was installed.
- Any replacement parts sold (not delivered under a warranty claim) will be subject to a warranty period of (6) six months from the date of invoice.
- Parts held by a Distributor are covered under warranty for a period of (12) twelve months from the date of invoice, provided that those parts have been subject to appropriate storage to prevent damage and deterioration.

CLAIM PROCEDURE

The Snorkel Warranty Department must be notified within (48) forty-eight hours of any possible warranty situation during the applicable warranty period. Personnel performing major warranty repair or parts replacement must obtain specific approval by the Snorkel Warranty Department prior to performing the warranty repair or replacement.

When a Distributor/Customer perceive a warranty issue to exist the following steps must be adhered to:

- All warranty claims must be submitted within 30 days of the date of the machine repair
- All correspondence in respect of the claim to be on an official Snorkel warranty claim form as supplied by Snorkel's Warranty Department
- Allocate a warranty claim number to the repair
- Place a purchase order for genuine Snorkel replacement parts
- Snorkel to dispatch parts via the requested method (in line with the required response time)
- Confirmation that a qualified technician is available to replace the part and that this person has been accepted by Snorkel to carry out such work under the warranty of the machine. Failure to do this may nullify the warranty.

FREIGHT DAMAGE

If a machine is received in a damaged condition, then the damage must be noted on the bill of lading and/or delivery documents and if possible photographs taken, prior to signing acceptance of the consignment. The freight company must be contacted by the Distributor and a damage claim registered immediately.

THIS WARRANTY EXCLUDES AND SNORKEL DOES NOT WARRANT:

1. Engines, motors, tires and batteries are manufactured by suppliers to Snorkel, who furnish their own warranty. Snorkel will, however, to the extent permitted; pass through any such warranty protection to the Distributor/Customer.
2. Any Snorkel product which has been modified or altered outside Snorkel factory without Snorkel written approval, if such modification or alteration, in the sole judgment of Snorkel Engineering and/or Service Departments, adversely affects the stability, reliability or service life of the Snorkel product or any component thereof.



Product Warranty

3. Any Snorkel product which has been subject to misuse and abuse, improper maintenance or accident. "Misuse" includes but is not limited to operation beyond the factory-rated load capacity and speeds. "Improper maintenance" includes but is not limited to failure to follow the recommendations contained in the Snorkel Operator's and Repair Parts Manuals.
4. Normal wear of any Snorkel component part(s). Normal wear of component parts may vary with the type, application or type of environment in which the machine may be used; such as, but not limited to sandblasting applications.
5. Routine maintenance, routine maintenance items and minor adjustments are not covered by this warranty, including but not limited to hydraulic fluid, filters and lubrication, paint and decals.
6. Any Snorkel product that has come into direct contact with any chemical or abrasive material.
7. Incidental or consequential expenses, losses, or damages related to any part or equipment failure, including but not limited to freight cost to transport the machine to a repair facility, downtime of the machine, lost time for workers, lost orders, lost rental revenue, lost profits, expenses or increased cost. This warranty is expressly in lieu of all other warranties, representations or liabilities of Snorkel, either expressed or implied, unless otherwise amended in writing by Snorkel.
8. Snorkel Warranty policy does not cover any duties, taxes, environmental fees including without limitation, disposal or handling of tires, batteries and petrochemical items.
9. Item specifically excluded are, fuel injectors, motor brushes, glow plugs, contactor tips and springs, oil filters, lamp bulbs, lamp lenses, O-rings, coolants, lubricants and cleaning material.
10. Failure of replacement parts due to fault misdiagnosis or incorrect fitting by the Distributor/Customer.

SNORKEL MAKES NO WARRANTIES WHICH EXTEND BEYOND THE DESCRIPTION OF THIS LIMITED WARRANTY

SNORKEL MAKES NO IMPLIED WARRANTY OF MERCHANTABILITY OR FITNESS FOR A PARTICULAR PURPOSE AND DISCLAIMS ALL LIABILITY FOR INCIDENTAL OR CONSEQUENTIAL DAMAGES, INCLUDING BUT NOT LIMITED TO INJURY TO PERSONS OR PROPERTY.

The Customer shall make all warranty claims through Snorkel directly or an Authorised Distributor. If unable to contact the Distributor, contact the Snorkel Service Department for further assistance.



Product Warranty

APPEAL

The buyer may appeal in writing against a rejected or adjusted claim to Snorkel Warranty Department within a period of 21 days of receiving the rejection or adjustment notice. The appeal should be grounded on express reasons and supported by relevant evidence. Appeals received outside of this time limit will not be considered.

WARRANTY SCHEDULE

Limited Warranty Periods

Item	Warranty Period
New machine materials and workmanship	1 year parts replacement
Structural components (Chassis, Turntable, Booms, Scissors)	5 years parts replacement or repair
Parts held in a Distributor's stock	12 months from date of invoice
Parts sold (non warranty)	6 months from date of invoice
Batteries	6 months from date of invoice
Other specifically excluded parts: Fuel injectors Motor brushes Glow plugs Contactor tips and springs Oils Filters Lamp bulbs Lamp lenses O-rings Coolants Lubricants Cleaning materials	Not covered by Warranty

**Local Distributor / Lokaler Vertiebs Händler / Distributeur local
El Distribuidor local / Il Distributore locale**

**EUROPE, MIDDLE EAST
AFRICA & ASIA**

**PHONE: +44 (0) 845 1550 058
FAX: +44 (0) 845 1557 756**

NORTH & SOUTH AMERICA

**PHONE: +1 785 989 3000
TOLL FREE: +1 800 255 0317
FAX: +1 785 989 3070**

AUSTRALIA

**PHONE: +61 1300 700 450
FAX: +61 2 9609 3057**

NEW ZEALAND

**PHONE: +64 6 3689 168
FAX: +64 6 3689 164**



www.snorkellifts.com